



Classifying Sensitive Overhead Power Lines According to Their Impact on Cost Functions to Enhance Their Protection through Dandelion Optimization

Mohamed BEY^{1*} , Amina Tamer²

¹L2GEGI Laboratory, Applied sciences Faculty, IBN Khaldoun University of Tiaret, Algeria.

²Higher School of Electrical and Energetic Engineering of Oran, Algeria.

ABSTRACT: This article examines the objective function of power generation, focusing on the impact of overhead line failures (line outages) on its value, which may either decrease or increase depending on the line's criticality. This study proposes the Dandelion Optimization algorithm to evaluate system performance and identify the most critical transmission lines that require careful maintenance to reduce high generation costs. A novel performance index is established to assess the impact of line failure and identify the lines that warrant the most attention. This research uses the IEEE 30-bus power network as a case study to validate the proposed concept, which demonstrates that overhead electric transmission lines do not hold equal significance within the power network.

Review History:

Received: Jun. 12, 2025

Revised: Nov. 22, 2025

Accepted: Dec. 20, 2025

Available Online: Apr. 04, 2026

Keywords:

Objective Function

Failure

Overhead line

Outage

Dandelions Optimizer

1- Introduction

The prevalent energy market conditions lead to astronomical power generation costs, making energy cost the primary concern in the electrical energy sector today [1, 2]. The cost of a kilowatt-hour in fifteen European nations increased nearly tenfold when compared with the first half of 2023, as reported by the European Commission on April 24, 2024 [3]. Kelly also highlights this issue in January 2025 in the United States. Electricity prices have risen across the country, with Oregon experiencing a spike of up to 15% despite massive investments in renewable energy [4]. Power prices in Asian countries are also rising rapidly, raising concerns about potential impacts on their economies and industrial output [5].

Previously, when gas prices were much lower, studies such as [6-8] did not take price into account and instead concentrated on meeting demand and maintaining network stability. Currently, production cost has become a crucial factor in assessing the different states of networks, frequently represented in research as the objective function for optimal distribution. Therefore, this paper examines the influence of emergency states on the energy cost function. Power flow optimization represents a crucial domain of inquiry for specialists and administrators in power systems. Optimization often focuses on minimizing operational expenses; however,

the operation of power plants, especially thermal units, generates various types of emissions. The environmental challenge requires the reduction of emissions from thermal power plants, whether addressed individually for a single objective or simultaneously for multiple objectives. Cost reduction, loss minimization, and emission control may present conflicting goals, requiring decisions based on thorough multi-objective optimization. The Optimal Power Flow (OPF) is widely employed for decision-making by different operators in the electrical system [7, 8]. The complexity of the OPF problem in a deregulated electricity market, exacerbated by new constraints for reducing pollutant emissions (Kyoto Protocol, 2005) and the integration of renewable energy sources, makes the use of precise solution methods difficult. Traditional approaches often lack the flexibility to address various specific constraints. These challenges have led to the development of a new class of optimization techniques termed metaheuristic, which represent significant progress in the field. These methods are applicable not only to combinatorial problems but also to continuous optimization problems [9]. Analyzing critical conditions or contingencies is essential in electrical network studies. This analysis is based on various scenarios of potential failures within the network; with the most critical being the disruption of overhead lines or cables. The outcomes of such studies allow network operators to evaluate the effects of faults and take measures to restore essential grid components, specifically voltage and

*Corresponding author's email: mohamed.bey@univ-tiaret.dz



frequency, to acceptable levels until normal conditions are reinstated [10, 11].

In addition to these challenges, a key contribution of this work is the integration of the Dandelion Optimization (DO) algorithm into the OPF framework for contingency analysis. To the best of our knowledge, this constitutes the first application of DO for identifying critical transmission lines based on cost sensitivity. Furthermore, we introduce a novel Performance Index (PI) designed to quantify the impact of line outages on the cost function, providing operators with an additional decision-support tool. This dual contribution reinforces the originality and practical relevance of the proposed approach.

This study involves the implementation of the Dandelion Algorithm (DA). This method has been effectively applied to optimize various physical systems, as shown in [12], where the authors employ this approach to classify biomedical issues, including the input weights and output offsets of extreme learning machines. The authors in [13] utilize this technique to achieve optimal burden distribution at the furnace throat. A subsequent investigation into the optimization of linear antenna arrays using this method is presented in [14]. In the context of renewable energy, specifically solar energy, a study presented in [15] demonstrates the application of an optimization method aimed at enhancing the Maximum Power Point Tracking (MPPT) under shaded conditions. The optimal control of static converters is a significant focus in current research, particularly due to the emergence of various forms and structures of converters. The authors in [16] the efficiency of cascade H-bridge multilevel inverters (MLIs) enhance the performance of this optimization algorithm by integrating it with another method to achieve optimal control of a multilevel converter. The results obtained indicate a notably improved THD when compared to genetic algorithms. This study demonstrates the effectiveness of the method in comparison to alternative approaches, such as MOAs, with a reduction in convergence time by 0.4 seconds without any misses. These studies demonstrate the effectiveness of this optimization strategy relative to alternative approaches. A comparative study evaluated the efficacy of the proposed approaches relative to the classical genetic algorithm, emphasizing solution quality and convergence rate. The findings indicated satisfactory results in reducing production costs, transmission losses, and maintaining voltage profiles under both steady-state and contingency conditions. This work aims to analyze the impact of a line outage on the objective function of Optimal Power Flow (OPF). Currently, we are refining the proposed method and integrating a performance index to identify the line necessitating closer examination due to its failure, which will substantially elevate the cost function. The findings have been validated through the application of the IEEE 30-Bus system. The structure of this document is as follows: Section I addresses the issue of OPF, while Section II examines Dandelion Optimization (DO) techniques and details their implementation. Section III presents the results of various scenarios from the case study, followed by concluding remarks.

2- Optimal Power Flow Problem Formulation

The objective of the Optimal Power Flow (OPF) is to ensure the optimal steady-state operation of an electric power system by adjusting a set of control variables while satisfying specific operational and performance constraints. This constitutes a nonlinear programming problem that may be mathematically articulated as an objective function representing the generation cost:

$$\text{Minimize } f(x, u) \tag{1}$$

Under conditions:

$$\begin{cases} g(x, u) = 0 \\ h(x, u) \leq 0 \end{cases} \tag{2}$$

Such as: f it's the objective function,
 g : represents the constraints of equalities,
 h : these are the inequality constraints.
 x : is the vector of state variables,
 u : is the vector control variables.

2- 1- Control and Status Variables

The control variables typically include the voltage magnitudes or reactive powers produced at the generator bus bars, the transformer ratios of the load controllers, the phases of the phase-shifting transformers, and the reactive powers generated by various compensators for reactive energy. The status variables are the magnitudes of the load bus voltages and the angles of all voltages, excluding the reference bus bar [17, 18].

2- 2- Economic Dispatching with Active Power Loss and Penalty Factor

We define the problem by establishing three main conditions:

$$F_t = \sum_{i=1}^N F_i (a_i + b_i P_{gi} + c_i P_{gi}^2) \tag{3}$$

With :

$$\begin{cases} \sum_{i=1}^N P_{gi} = P_D + P_L \\ P_{g \min} \leq P_{gi} \leq P_{g \max} \end{cases} \tag{4}$$

Where:

- F_t : Total objective function (generation cost)
- F_i : Cost Function of generator i
- a_i, b_i, c_i : Cost Coefficient of generator i
- P_{gi} : Active Power generated by unit i (MW)

P_D : Total active power demand (MW)
 P_L : Total active power losses (MW)
 P_{gmin}, P_{gmax} : Minimum and maximum generation limits of unit (MW)
 N : Total number of generating units

2- 3- The Lagrangian

The Lagrangian with respect to the generated power and the Lagrange multiplier λ is expressed as:

$$L(P_{gi}, \lambda) = F(P_{gi}) + \lambda \left(\sum_{i=1}^N P_{gi} - P_D - P_L \right) + \sum_{i=1}^N U_{imin} (P_{gimin} - P_g) + \sum_{i=1}^N U_{imax} (P_{gimax} - P_g) \tag{5}$$

With:

$$\begin{cases} P_{gi} < P_{gmax}, & U_{imax} = 0 \\ P_{gi} > P_{gmin}, & U_{imin} = 0 \end{cases} \tag{6}$$

$L(P_{gi}, \lambda)$: Lagrangian function
 λ : Lagrange multiplier (incremental cost of power)
 Where:

U_{imax}, U_{imin} : are the penalty factors (constraint on minimum and maximum power generation)
 Eq. (5) simplifies to:

$$L(P_{gi}, \lambda) = F(P_{gi}) + \lambda \left(\sum_{i=1}^N P_{gi} - P_D - P_L \right) \tag{7}$$

By setting the Lagrangian derivative as a function of the generated power and equating λ to zero, we obtain:

$$\begin{cases} \frac{\partial L}{\partial P_{gi}} = 0 \\ \frac{\partial L}{\partial \lambda} = 0 \end{cases} \tag{8}$$

The first derivative is expressed as follows:

$$\frac{\partial L}{\partial P_{gi}} = 0 = \frac{\partial F_i}{\partial P_{gi}} + \lambda \left(0 + \frac{\partial L}{\partial P_{gi}} - 1 \right) \tag{9}$$

With:

$$\frac{\partial F_i}{\partial P_{gi}} = \frac{\partial (F_1 + F_2 + F_3 + \dots + F_N)}{\partial P_{gi}} = \frac{\partial F_i}{\partial P_{gi}} \tag{10}$$

One can draw the λ value:

$$\lambda = \frac{\partial F_i}{\partial P_{gi}} + \lambda \frac{\partial P_L}{\partial P_{gi}} = \left(\frac{1}{1 - \frac{\partial P_L}{\partial P_{gi}}} \right) \frac{\partial F_i}{\partial P_{gi}} \tag{11}$$

Thus, the expression $\left(\frac{1}{1 - \frac{\partial P_L}{\partial P_{gi}}} \right)$ is referred to as the penalty

factor, which fundamentally depends on the spatial positioning of the plants concerning the load.

The minimum cost is obtained when the incremental cost of each plant, multiplied by its penalty factor, is uniform across all operating generating units [17, 18]. The Eq. (8) is expressed in the following simplified form:

$$\lambda = PF_i \frac{dF_i}{dP_{gi}} \tag{12}$$

According to Eq. (12), the derivative shows the increase in generation cost associated with an increase in load demand. This value is more relevant than the previously defined incremental cost, as it takes system losses into account. Therefore, the criterion for distributing power packets is to identify the minimum corrected incremental cost [19].

3- Review of Dandelion Method

In DO, three types of operators are defined: the regular sowing operator, the mutation sowing operator, and the selection operator. This section focuses on minimization problems and introduces these operators [20, 21].

3- 1- Normal Seed Operator

Initially, it is essential to determine the number of seeds generated by the dandelion. The calculation for Dandelion X_i is given as:

$$N_{si} = \begin{cases} N_{smax} \frac{F_{max} - F(x_i) + \epsilon}{F_{max} - F(x_i) + \epsilon'}, & N_{si} > N_{smin} \\ N_{smin}, & N_{si} \leq N_{smax} \end{cases} \tag{13}$$

F_{max} and F_{min} are designated as the maximum and lowest fitness, respectively, to ensure that the number of seeds is neither excessive nor insufficient. Two parameters, N_{smax} and N_{smin} , are established. In DO, the ‘‘Core Dandelion (CD)’’ corresponds to the minimum fitness value. The initial radius for CD is calculated dynamically as follows:

$$R_{CD}(i) = \begin{cases} U_b - L_b, & \text{if } i = 1 \\ [6pt]R_{CD}(i-1)d, & \alpha = 1 \text{ if } i > 1 \\ [6pt]R_{CD}(i-1)g, & \alpha \neq 1 \text{ if } i < 1 \end{cases} \quad (14)$$

Where: U_b and L_b denote the upper and lower boundaries of the search space, respectively; d and g represent the decline and growth factors, the parameter i indicates the i^{th} generation; and α simulates the growth pattern of dandelions, defined as follows:

$$\alpha = \frac{F_{CD}(i) + \epsilon}{F_{CD}(i-1) + \epsilon} \quad (15)$$

Where: $F_{CD}(i)$ and $F_{CD}(i-1)$ are the lowest fitness value in generation i and $i-1$ respectively. (ϵ) represents the machine epsilon to avoid a division by zero.

All dandelions except CD are referred to assistant dandelions (ADs). The seed radius for ADs is calculated as follows:

$$R_{AD}(i) = \begin{cases} U_b - L_n, & \text{if } i = 0 \\ [6pt]\mu R_{AD}(i-1) \\ + (\|x_{CD}\|_\infty - \|x_i\|_\infty), & \text{if } i \neq 0 \end{cases} \quad (16)$$

Where: $\|\bullet\|$ denotes the maximum absolute value across all dimensions of the dandelion, and (μ) is a weighting factor defined as:

$$\mu = 1 - \frac{E}{E_{max}} \quad (17)$$

E represents the current number of function evaluations, and E_{max} denotes the maximum number of function evaluations.

Sowing Operator

The CD uses an alternative method of seed propagation, specifically the mutation sowing operator, which produces mutant seeds in the following manner:

$$S_m = X_{CD}(1+L) \quad (18)$$

Here, S_M represents the quantity of mutation sowing, whereas L is a random variable according to the Lévy distribution.

3- 2- Mutation Seed Operator

In DO, CD must be preserved while the other dandelions are selected according to a selection probability ϑ which is

calculated as:

$$\vartheta = \frac{|F(X_i) - F_{avg}|}{\sum_{n=1}^{SA} F(X_n)} \quad (19)$$

Where: F_{avg} represents the average fitness of the current generation and SA denotes the set containing both normal and mutant dandelion seeds.

Upon introducing these operators, we obtain a comprehensive understanding of the overall DO framework defined in [20]. Initially, normal and mutant seeds are generated according to the algorithm, followed by the selection of N dandelions utilizing the selection technique.

4- Performance Index for Study Analysis

In an electrical network, there is a wide range of possible contingencies, some of which can cause a critical instability, while others may not be critical at all. In practice, though, only a small subset of these contingencies needs to be considered. Whenever one of these happens, we need methods that can filter based on the condition, and then we can analyze and classify the contingencies from most severe to least severe [10]. In this kind of analysis, researchers use performance indices to compare results [22, 23]. In this work, as mentioned earlier, we introduce a new performance index as follows:

$$P_i = \frac{F_{ci} - F}{\sum_{i=1}^n (F_{ci} - F)} \quad (20)$$

Where: F_{Ci} denotes the objective function in i^{th} contingency case and F represents: the objective function in the network's normal mode. This indicator provides valuable insight into the correlation between line outages and elevated costs, thereby identifying critical lines that require protection to prevent loss and enhance resilience, as well as those whose loss has negligible impact.

5- Simulations, Results and Discussions

5- 1- IEEE 30-bus Network Case

The simulation is carried out on the 30-bus test system as illustrated in Fig 1, following the methodology established in [24]. The model includes six generators located on buses 1, 2, 5, 8, 11, and 13, respectively. The network consists of 41 lines. The parameters for the electrical grid, including generation costs and emission coefficients, are taken from reference [25].

This simulation comprises two fundamental components: steady state and fault mode. The objective is to analyze the optimal distribution; consequently, various scenarios of an overhead line outages are examined. This study focus

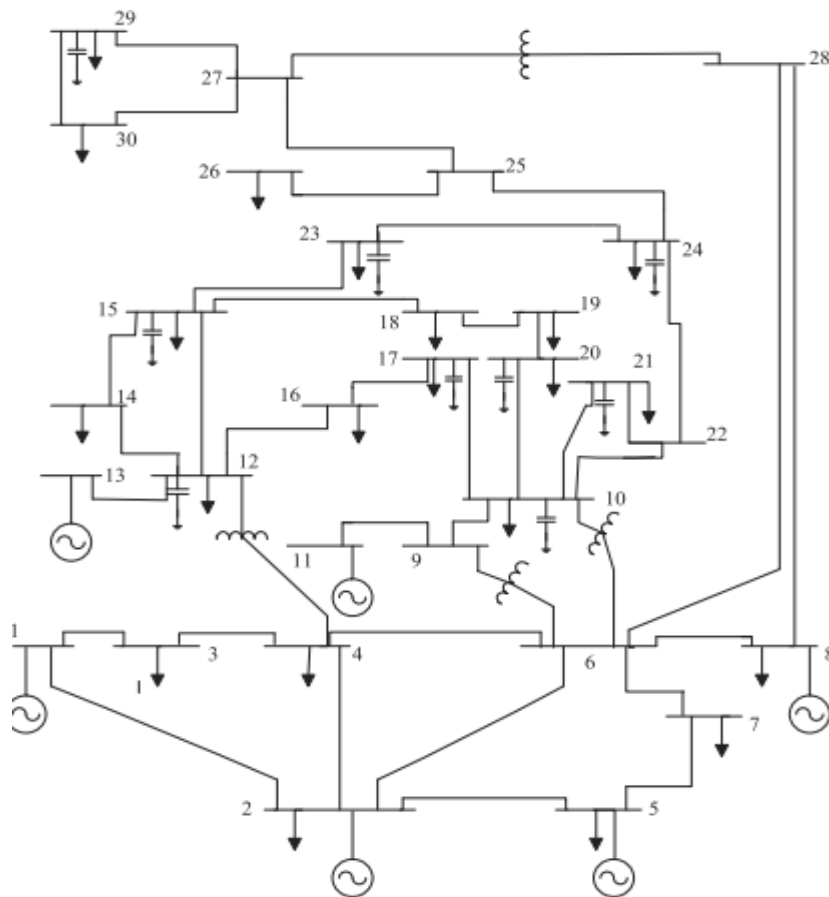

Fig. 1. Single line diagram of IEEE 30-Bus test system [25].

on identifying the critical line that may lead to significant increases in the objective function (cost) and/or in gas emissions.

5- 2- Study State Mode

Initially, a simulation is performed in the steady state of the network to compare the results obtained using the “DO” method with those derived from other methods, including the classical GA. This comparison confirms the effectiveness of the proposed method in determining the optimal power distribution among the stations for an objective function representing generation cost.

5- 3- Results

In the normal operating condition of the network, the proposed “DO” approach is applied to solve the OPF problem for a quadratic objective function that includes penalty factor. Fig. 2 illustrates the convergence of the method based on the objective function.

Fig. 3 shows the solution of the objective function using conventional “GA”; for comparison, the objective function is solved under the same condition and parameters as those applied with the DO method:

Table 1 summarizes the key findings to provide a clearer

understanding of the differences between the approaches:

Fig. 4 illustrates the optimal variable positions obtained by the two methods. The green line represents the proposed DO algorithm, while the red line corresponds to the GA. Each method provides its own set of optimal power outputs for the generating units, which highlights the distinct characteristics of the two approaches.

Fig. 5 illustrates the optimal allocation of generation among the power stations, whereas Table 2 displays the voltage magnitude at each bus.

5- 4- Discussions

The selection of classical GA optimization for comparison is due to its foundational role as a reference for metaheuristic methods. Fig. 2 and Fig. 3 illustrate that the DO method achieves an objective function value of 801.828, in contrast to the GA method, which yields a higher objective function value of 802.303. Furthermore, the DO method reaches this solution within 160 generations, whereas the GA method requires the full 200 generations to arrive at its solution.

Table 1 presents two significant observations: the active power losses calculated using the DO method are 9.3980 MW, which is lower than the 9.6980 MW obtained via the GA method. Notably, the precision of the production is superior

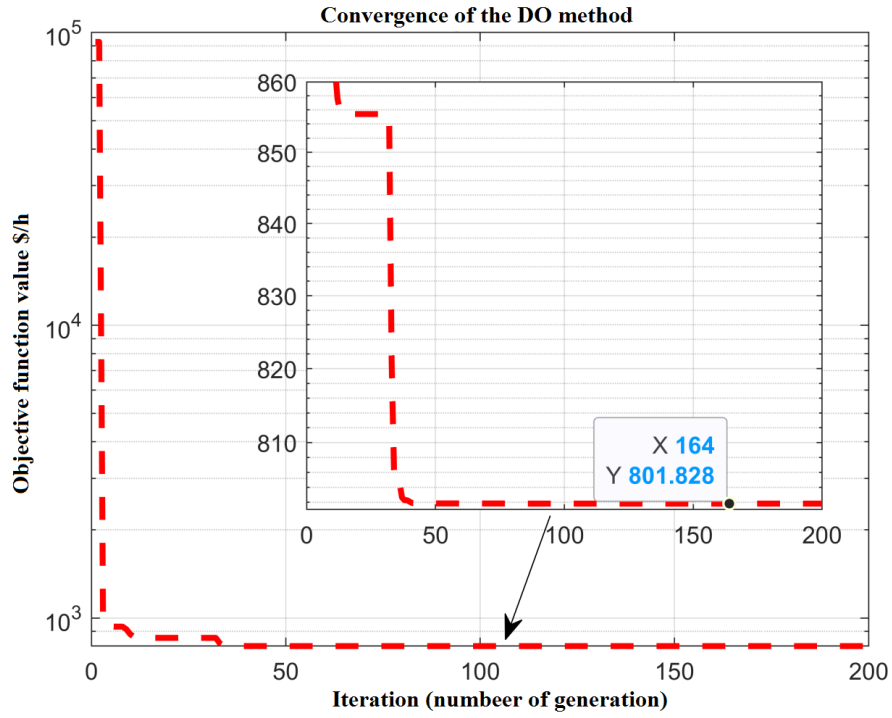

Fig. 2. Convergence behavior of the objective function using ‘DO’ method the method converge to 801.828 at generation 164.

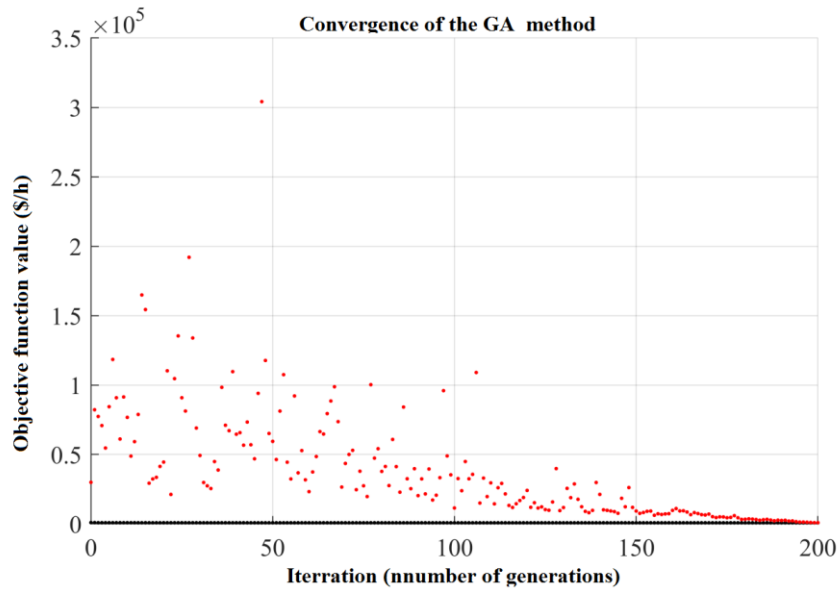

Fig. 3. Convergence behavior of the objective function using ‘GA’ method (the best solution obtained is 802.303 after 200 generations).

Table 1. Results obtained using the DO method versus the GA method.

Method	Objective function	Convergence Generation	Plosses	Max P Mismatch
DO	801.828	164	9.3980	0.0013938
GA	802.303	200	9.6980	0.0014424

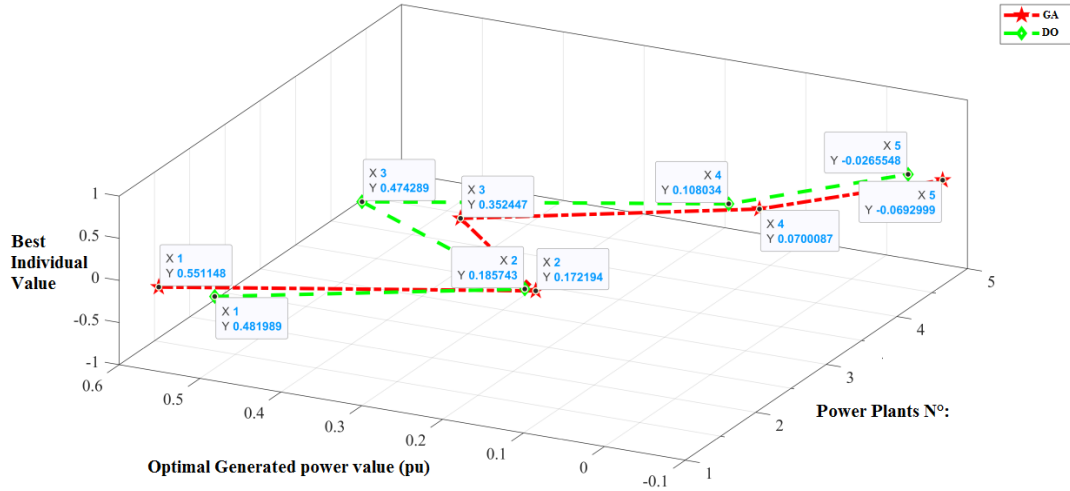

Fig. 4. Best individual position obtained by the DO and the GA methods for the five generating units.

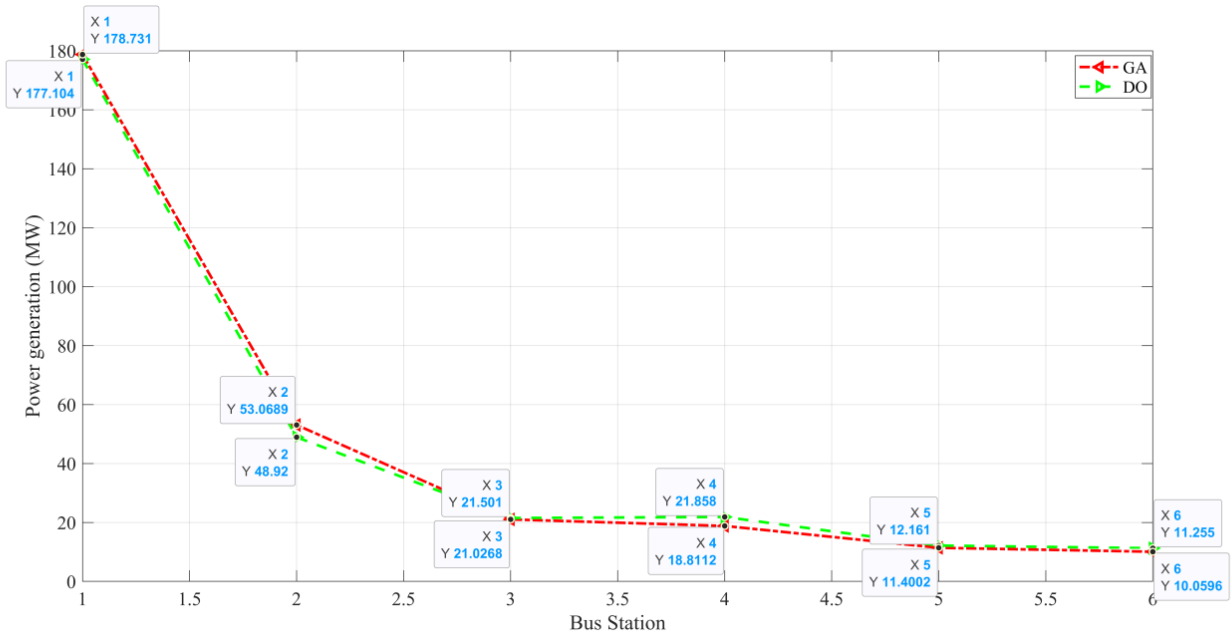

Fig. 5. Optimal Active Power Generation (MW).

Table 2. Magnitude Voltage profile at all buses.

Bus	DO method	GA method
1	1.060	1.060
2	1.043	1.043
3	1.025	1.025
4	1.017	1.017
5	1.010	1.010
6	1.015	1.015
7	1.005	1.005
8	1.010	1.010
9	1.053	1.053
10	1.047	1.047
11	1.082	1.082
12	1.060	1.060
13	1.071	1.071
14	1.045	1.045
15	1.040	1.040
16	1.047	1.047
17	1.042	1.042
18	1.030	1.030
19	1.028	1.028
20	1.032	1.032
21	1.034	1.034
22	1.035	1.035
23	1.030	1.029
24	1.024	1.024
25	1.020	1.020
26	1.003	1.003
27	1.027	1.027
28	1.013	1.013
29	1.007	1.007
30	0.996	0.996

in the DO method, exhibiting a tolerance of 0.0013938, in contrast to the GA method's tolerance of 0.0014424. The results are further clarified by Fig. 5, which illustrates the optimal power production of the two methods, DO and GA. It is evident that the DO method produces less power from the swing bus and compensates through other "PV" nodes. Whereas, the GA method allocate more production to the balance node. Table 2 indicates that the two methods provide nearly identical voltage profiles.

5- 5- Fault Mode

Secondly, we implement the DO algorithm in fault mode, represented by the outage of one line, excluding the lines between 13-12 and 9-11. The outage of these two lines leads to the complete loss of one power generation station. The line between 25 and 26 causes a total loss of the load. This study demonstrates the impact of overhead line outages on optimal power distribution, which directly influences the objective function value in each scenario. Table 3 summarizes the objective function and the active power losses for each case of line outage.

Table 3 provides several extractable insights. 1. The loss of a line leads to a redistribution of production among the plants; Table 4 gives examples of production in various cases. This finding helps managers in dispatch centers in forecasting and responding to potential losses of each overhead line.

2. It is observed that the removal of a line causes an increase in the objective function across all scenarios, indicating a higher generation costs. This increase classifies the line outage into three classifications:

- Critical cases: a significant increase in the objective function occurs in cases 1, 2, and 30, as illustrated in Fig. 6.
- Normal cases: the losses of specific lines result in an acceptable increase in the objective function for cases 14, 20, and 23 (see Fig. 7).
- Negligible case: illustrated in Fig. 8 indicates that the losses from specific lines, namely 21, 29, and 32, lead to only a minimal increase in the objective function.

Fig. 9 shows the PI index. From this index, it is clear that case No.35 exhibits the most significant increase in the objective cost function, with an estimated indicator of 0.1096. Consequently, the situation regarding the loss or breakdown of the 27-30 line requires careful consideration. Additionally, there are other lines whose loss produces a notable enhancement of the function, exemplified by cases 1, 16, 26, and 30. Conversely, there are instances where certain lines have minimal or no effect on the objective cost function, specifically in cases 3, 19, 21, 25, 27, 29, and 36. This analysis highlights the varying levels of criticality among transmission lines.

3. An important observation is that the relationship between the objective function and active power losses is inherently nonlinear. In certain cases, such as 1, 5, and 33, an increase in active power losses is observed. Conversely, cases 8, 15, and 35 show a decrease in active power losses. This observation suggests that specific lines, such as 5 and

6, are major contributors to higher active power losses, this nonlinear behavior must be considered when planning corrective strategies.

Fig. 10 illustrates the correlation among the cases, active power losses, and the PI index. This Fig. helps identify the critical lines that require attention, showing that case 35 indicates the line between 27 and 30 as the weakest link among all lines.

6- Conclusion

Due to the abrupt fluctuations in global energy prices impacting electricity production costs, this study analyses the effect of the emergency situation on the objective function. We proposes a novel approach to calculate optimal power flow and energy distribution among power plants, specifically the Dandelion Optimization method. To validate its effectiveness, we compared the results obtained with those from a similar study utilizing the classical GA method, which serves as the primary reference for this type of analysis. The comparison demonstrates the method's efficiency across various metrics, including convergence time, power mismatch, objective function, and active power losses. Subsequently, we implemented the contingency model, focusing on the failure of a single overhead electric line. We identified the most vulnerable line that requires reinforcement and close monitoring, as any failure or defect in this line leads to a significant increase in the price function. This analysis shows that the critical line in the approved system is located between points 27 and 30. Beyond these findings, the introduction of the new Performance Index provides a complementary tool for ranking critical lines based on cost sensitivity, which enhances decision-making for system operators. These elements reinforce the novelty and practical relevance of the proposed approach. The next step is to analyses additional emergency cases and their effects on the objective function, develop an optimal distribution plan for each case, and suggesting measures to enhance the weakest link, including the implementation of FACTS devices.

References

- [1] A. Ari et al., "Surging energy prices in Europe in the aftermath of the war: How to support the vulnerable and speed up the transition away from fossil fuels," IMF Working Papers, International Monetary Fund, Washington,DC,2022,doi:10.5089/9798400214592.001.
- [2] N. Butler, "The impact of the Ukraine war on global energy markets," Centre for European Reform, 2022. [Online]. Available: <https://www.cer.eu/insights/impact-ukraine-war-global-energy-markets>. [Accessed: Apr. 12, 2025].
- [3] S. Brown and D. Jones, "European Electricity Review 2024," Ember, 2024. [Online]. Available: <https://ember-energy.org/latest-insights/european-electricity-review-2024>. [Accessed: Apr. 12, 2025].
- [4] M. Pressler, "Cost of electricity by state, electric rates by state," Quick Electricity. [Online]. Available: <https://>

Table 3. Objective function and active power losses for each line outage in fault mode.

line N° :	Objective function (MW/€)	Plosses (MW)	Performance Index	Classification
1 (bus1-bus2)	849.9485	14.0830	0.0640	Critical
2 (bus1-bus3)	844.8128	9.9510	0.0572	Critical
3 (bus2- bus 4)	804.0127	9.8840	0.0029	Negligible
4 (bus 3- bus 4)	836.3064	10.9870	0.0459	Normal
5 (bus 2- bus 5)	837.2026	17.7960	0.0470	Normal
6 (bus 2- bus 6)	827.2032	10.9220	0.0337	Normal
7 (bus 4- bus 6)	806.6246	10.3750	0.0064	Negligible
8 (bus 5- bus 7)	836.9284	8.0110	0.0467	Normal
9 (bus 6- bus 7)	806.6764	10.8510	0.0064	Negligible
10 (bus 6- bus 8)	814.508	7.5840	0.0169	Negligible
11 (bus 6- bus 9)	825.6685	8.9150	0.0317	Normal
12 (bus 6- bus 10)	814.8315	7.6910	0.0173	Negligible
13 (bus 9- bus 10)	803.3099	9.8480	0.0020	Negligible
14 (bus 4- bus 12)	805.2143	10.0680	0.0045	Negligible
15 (bus 12- bus 14)	831.2768	7.9320	0.0392	Normal
16 (bus 12- bus 15)	857.7181	8.4770	0.0743	Critical
17 (bus 12- bus 16)	821.5204	9.5800	0.0262	Normal
18 (bus 14- bus 15)	825.0086	8.7590	0.0308	Normal
19 (bus 16- bus 17)	803.9509	8.7390	0.0028	Negligible
20 (bus 15- bus 18)	810.9606	8.7670	0.0121	Negligible
21 (bus 18- bus 19)	801.8841	9.4120	0.0007	Negligible
22 (bus 19- bus 20)	802.7396	9.6660	0.0012	Negligible
23 (bus 10- bus 20)	805.4251	9.1770	0.0048	Negligible
24 (bus 10- bus 17)	821.6339	9.6280	0.0263	Normal
25 (bus 10- bus 21)	803.0751	9.7580	0.0017	Negligible
26 (bus 10- bus 22)	855.6708	7.8790	0.0716	Critical
27 (bus 21- bus 22)	803.9105	8.7270	0.0028	Negligible
28 (bus 15- bus 23)	825.6133	8.9300	0.0316	Normal
29 (bus 22- bus 24)	802.2248	9.5140	0.0005	Negligible
30 (bus 23- bus 24)	855.4391	7.8080	0.0713	Critical
31 (bus 24- bus 25)	803.8648	8.7120	0.0027	Negligible
32 (bus 25- bus 27)	802.3052	9.5380	0.0006	Negligible
33 (bus 28- bus 27)	810.7464	10.7630	0.0119	Negligible
34 (bus 27- bus 29)	856.6340	8.1660	0.0729	Critical
35 (bus 27- bus 30)	884.2609	7.5530	0.1096	Highest Critical
36 (bus 29- bus 30)	802.2699	9.5250	0.0005	Negligible
37 (bus 8- bus 28)	821.0934	9.4630	0.0256	Normal
38 (bus 6- bus 28)	811.5610	8.9140	0.0129	Negligible

Table 4. Optimal power generation for selected contingency cases.

Case	Pg1 (MW)	Pg2 (MW)	Pg3 (MW)	Pg4 (MW)	Pg5 (MW)	Pg6 (MW)
11	162.449	45.391	20.421	13.523	10.531	40.000
27	169.100	46.969	20.889	35.000	10.483	9.685
33	170.319	47.252	20.970	35.000	10.761	9.861

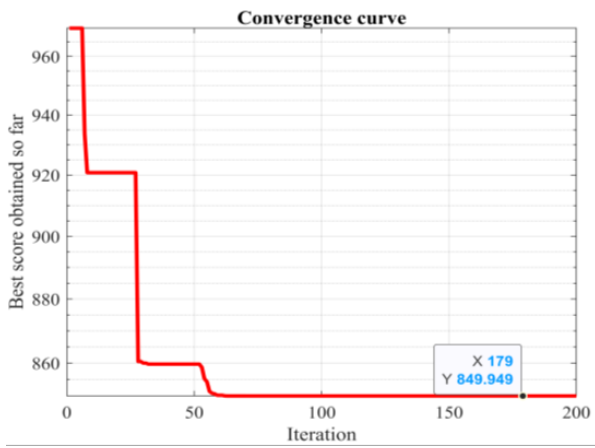

(a)

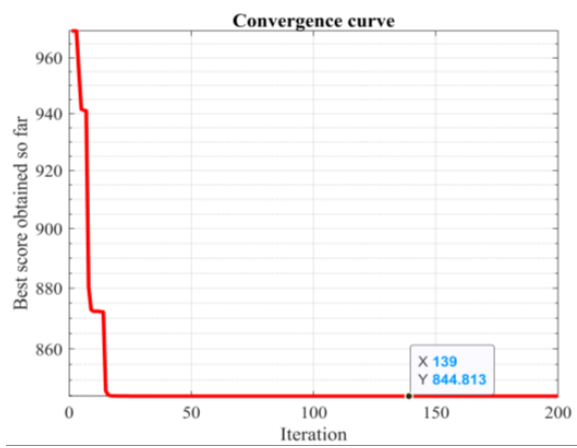

(b)

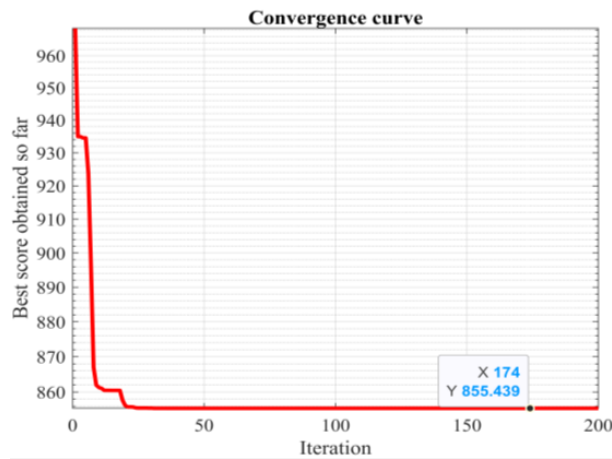

(c)

Fig. 6. Critical line outage cases: (a) case 1, (b) case 2, (c) case 30.

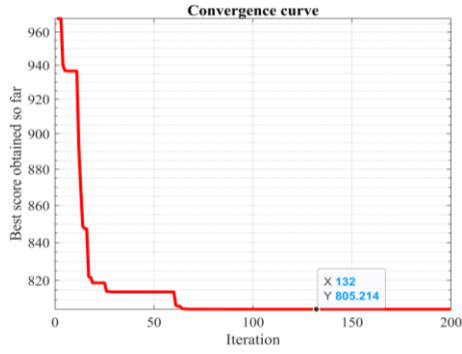

(a)

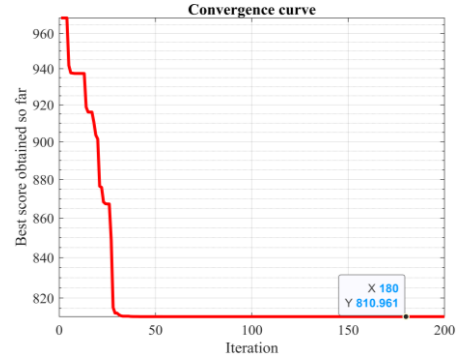

(b)

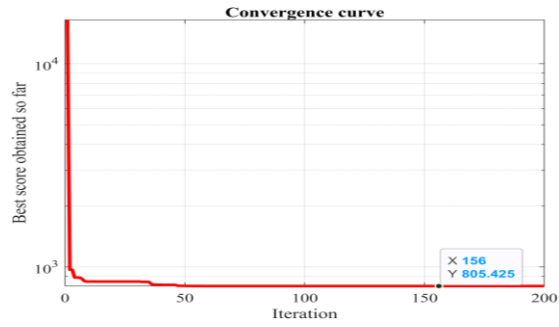

(c)

Fig. 7. Normal line outage cases: (a) case 14, (b) case 20, (c) case 23.

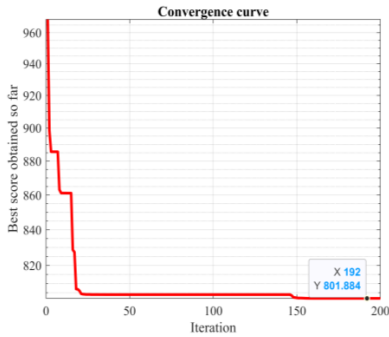

(a)

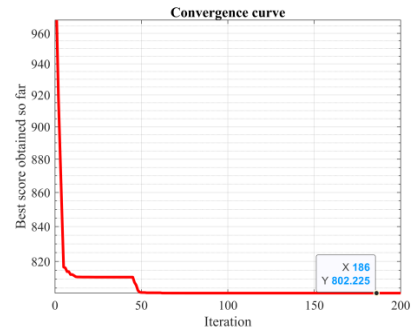

(b)

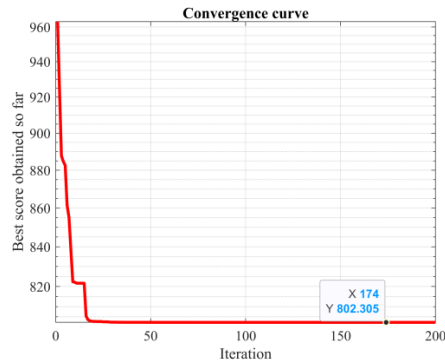

(c)

Fig. 8. Negligible line outage cases: (a) case 21, (b) case 29, (c) case 32.

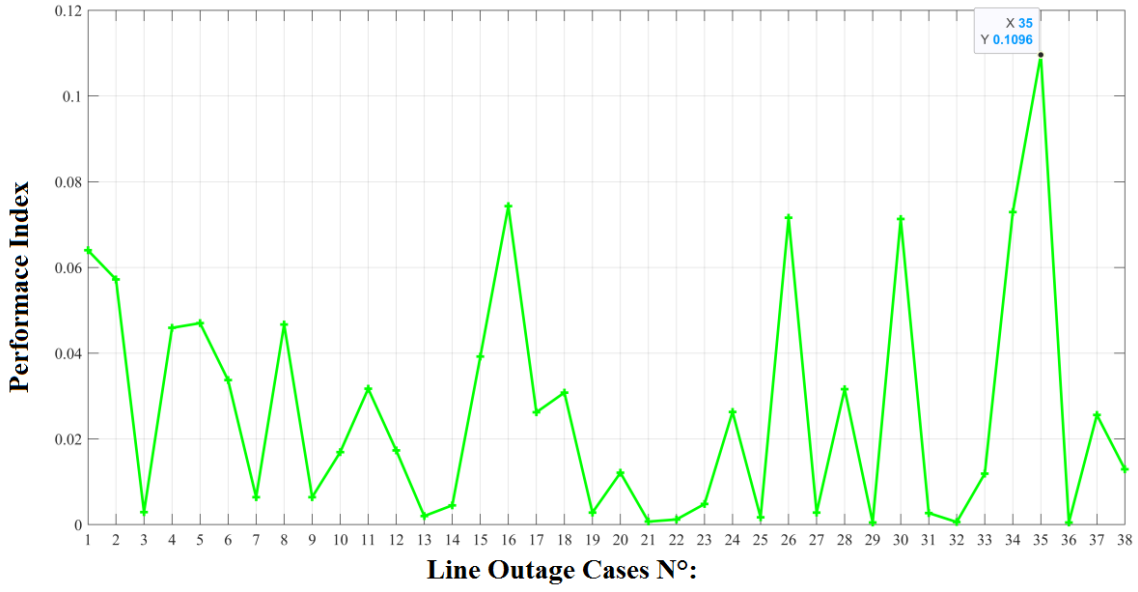

Fig. 9. Performance Index (PI) values for all 38 line outage cases. The highest Pi Value (0.1096) occurs in case 35.

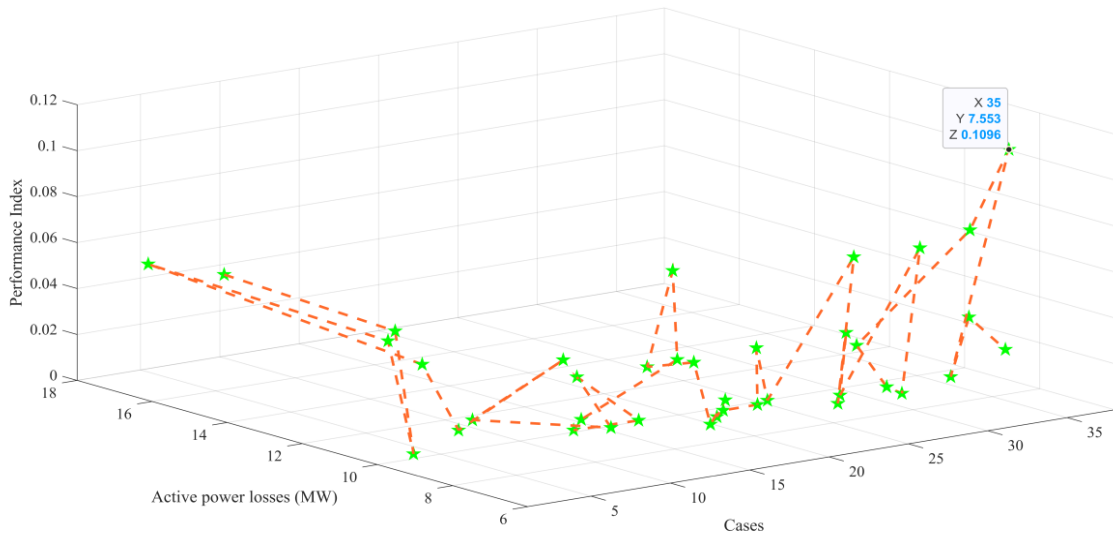

Fig. 10. Correlation between active power losses and performance index (PI) values for different line outage cases. Line (27-30) identifying as the weakest contingency in the system.

- quickelectricity.com/cost-of-electricity-by-state/. [Accessed: Apr. 12, 2025].
- [5] V. Tachev, "The impacts of the electricity price increase on Asian countries," *Energy Tracker Asia*. [Online]. Available: <https://energytracker.asia/the-impacts-of-the-electricity-price-increase-on-asian-countries/>. [Accessed: Apr. 12, 2025].
- [6] S. Kumar, B. Tyagi, V. Kumar, and S. Chohan, "PMU-based voltage stability measurement under contingency using ANN," *IEEE Trans. Instrum. Meas.*, vol. 71, pp. 1–11, 2022, doi: 10.1109/TIM.2021.3129210.
- [7] M. Ntombela, K. Musasa, and M. C. Leoaneka, "Power loss minimization and voltage profile improvement by system reconfiguration, DG sizing, and placement," *Computation*, vol. 10, no. 10, p. 180, Oct. 2022, doi: 10.3390/computation10100180.
- [8] Y. Siregar and A. J. Aritonang, "Optimization of location, capacity, and number of UPFC in the 150 kV SUMBAGUT transmission system by using particle swarm optimization," in *Proc. 11th EECCIS, Malang, Indonesia, Aug. 2022*, pp. 28–33, doi: 10.1109/EECCIS54468.2022.9902890.
- [9] B. Ismail et al., "A comprehensive review on optimal location and sizing of reactive power compensation using hybrid-based approaches for power loss reduction, voltage stability improvement, voltage profile enhancement and loadability enhancement," *IEEE Access*, vol. 8, pp. 222733–222765, 2020, doi: 10.1109/ACCESS.2020.3043297.
- [10] D. Hazarika, S. Bhuyan, and S. P. Chowdhury, "Line outage contingency analysis including the system islanding scenario," *Int. J. Electr. Power Energy Syst.*, vol. 28, no. 4, pp. 232–243, May 2006, doi: 10.1016/j.ijepes.2005.11.018.
- [11] Y. Yang et al., "Parallel computing of multi-contingency optimal power flow with transient stability constraints," *Prot. Control Mod. Power Syst.*, vol. 3, no. 1, p. 20, Dec. 2018, doi: 10.1186/s41601-018-0095-z.
- [12] X. Li, S. Han, L. Zhao, C. Gong, and X. Liu, "New dandelion algorithm optimizes extreme learning machine for biomedical classification problems," *Comput. Intell. Neurosci.*, vol. 2017, pp. 1–13, 2017, doi: 10.1155/2017/4523754.
- [13] L. Wang, Y. Zhang, and D. Lv, "Dandelion optimizer based decision method of burden distribution matrix in blast furnace iron-making process," in *Proc. 35th CCDC, Yichang, China, May 2023*, pp. 239–245, doi: 10.1109/CCDC58219.2023.10327446.
- [14] J. Li, Y. Liu, T. Zhu, and W. Zhao, "Optimize linear antenna arrays with dandelion optimization algorithm," in *Proc. IEEE ICEIEC, Beijing, China, Jul. 2023*, pp. 144–147, doi: 10.1109/ICEIEC58029.2023.10200787.
- [15] A. M. Eltamaly, Z. A. Almutairi, and M. A. Abdelhamid, "Modern optimization algorithm for improved performance of maximum power point tracker of partially shaded PV systems," *Energies*, vol. 16, no. 13, 2023, doi: 10.3390/en16135228.
- [16] M. Saglam, Y. Bektas, and O. A. Karaman, "Dandelion optimizer and gold rush optimizer algorithm-based optimization of multilevel inverters," *Arab. J. Sci. Eng.*, vol. 49, no. 5, pp. 7029–7052, May 2024, doi: 10.1007/s13369-023-08654-3.
- [17] N. Kumar, R. Kumar, and R. Kumar, "A review on optimal power flow problem," in *Microelectronics, Circuits and Systems*, vol. 976, A. Biswas et al., Eds., *Lecture Notes in Electrical Engineering*. Singapore: Springer, 2023, pp. 35–50, doi: 10.1007/978-981-99-0412-9_4.
- [18] Z. Yang et al., "Mapping between transmission constraint penalty factor and OPF solution in electricity markets: analysis and fast calculation," *Energy*, vol. 168, pp. 1181–1191, Feb. 2019, doi: 10.1016/j.energy.2018.11.048.
- [19] M. Ghasemi et al., "Multi-objective optimal power flow considering the cost, emission, voltage deviation and power losses using multi-objective modified imperialist competitive algorithm," *Energy*, vol. 78, pp. 276–289, Dec. 2014, doi: 10.1016/j.energy.2014.10.007.
- [20] S. Han, K. Zhu, and R. Wang, "Improvement of evolution process of dandelion algorithm with extreme learning machine for global optimization problems," *Expert Syst. Appl.*, vol. 163, p. 113803, Jan. 2021, doi: 10.1016/j.eswa.2020.113803.
- [21] J. Sabattin, C. Contreras Bolton, M. Arias, and V. Parada, "Evolutionary optimization of electric power distribution using the dandelion code," *J. Electr. Comput. Eng.*, vol. 2012, p. 738409, 2012, doi: 10.1155/2012/738409.
- [22] Z. Wang, A. Younesi, M. V. Liu, G. C. Guo, and C. L. Anderson, "AC optimal power flow in power systems with renewable energy integration: A review of formulations and case studies," *IEEE Access*, vol. 11, pp. 102681–102712, 2023, doi: 10.1109/ACCESS.2023.3314330.
- [23] C. Yang et al., "Optimal power flow in distribution network: A review on problem formulation and optimization methods," *Energies*, vol. 16, no. 16, p. 5974, Aug. 2023, doi: 10.3390/en16165974.
- [24] S. Zhao, T. Zhang, S. Ma, and M. Chen, "Dandelion optimizer: A nature-inspired metaheuristic algorithm for engineering applications," *Eng. Appl. Artif. Intell.*, vol. 114, p. 105075, Sep. 2022, doi: 10.1016/j.engappai.2022.105075.
- [25] M. Shahidehpour and Y. Wang, *Communication and Control in Electric Power Systems*, 1st ed. Hoboken, NJ, USA: Wiley, 2003, doi: 10.1002/0471462926.

HOW TO CITE THIS ARTICLE

M. BEY, A. Tamer, *Classifying Sensitive Overhead Power Lines According to Their Impact on Cost Functions to Enhance Their Protection through Dandelion Optimization*, *AUT J. Elec. Eng.*, 58(2) (2026) 281-296.

DOI: [10.22060/ej.2025.24280.5669](https://doi.org/10.22060/ej.2025.24280.5669)



