



## Optimum scheduling of the HRES for an isolated rural city in Iran

A. Alimardani, Sh. Jadid

Iran University of Science and Technology, Tehran, Iran

**ABSTRACT:** It is necessary to form an energy system in order to deliver the electrical power to a region to which delivering energy from the national grid is not possible. At the moment, using the hybrid renewable energy systems (HRES) is the suggestion of many articles and scientific books because of environmental problems, nearing the end of fossil fuels, and challenges, including the unpredictability of the renewable resources. In order to optimize the operation of a PV-diesel-battery energy system in the paper, a practical model has been proposed to optimal day-ahead scheduling diesel generator in a PV-diesel-battery system. Due to the uncertainty of the solar prediction data, it has been considered by Monte-Carlo simulation in the day-ahead diesel generator scheduling model (DDSM). The model has been implemented for PV-diesel-battery system on a sample desert area in Kerman in Iran. The area load modeling has been done by predicting electrical consumption of some days of the seasons that are the symbols of all days of the seasons. Annual and five-year environmental, economic, and technical indexes have been computed and the results have been compared using the indexes in different reliability and storing capacity scenarios. Sensitivity analysis of the results has been done for the PV-diesel-battery system.

### Review History:

Received: 11 January 2018

Revised: 16 November 2018

Accepted: 11 March 2019

Available Online: 11 March 2019

### Keywords:

Hybrid renewable energy systems (HRES)  
diesel generator  
day-ahead scheduling model  
uncertainty  
pollution

### 1- Introduction

Development of many rural communities needs reliable and stable electricity supply [1]. On the other hand, based on recent World Bank's and IEA reports, the national grid is not accessible to a global average of 22% that most of them are dwellers of rural communities. The extension of the main grid supply to these remote regions could be costly and impractical. Geographical terrain and distance exacerbate the challenges of grid extension. Justifying the cost of such a grid extension usually is not possible considering the population of these remote regions [2]. As a result, forming off-grid energy systems is a reasonable solution. Traditionally, only diesel generators have supplied the remote communities but nowadays the interest in renewable energy resources (RES) has increased. The reasons for the interest include five groups:

- Increasing energy demand: It is predicted that the energy demand in the world will rise by 56% from 2010 to 2040[3].
- Global pollution concerns: It is predicted that the carbon dioxide emissions will rise approximately by 46% from 2010 to 2040[3].
- Finite resources of fossil fuels and oil price increase [1], [3].
- Risks of nuclear power stations: Human health risks relevant to nuclear power stations is a serious problem to extend it [3].
- Prevention of external dependency [3].

Thus choosing hybrid renewable energy systems (HRES) for supplying a remote communication is more economic and

technical than choosing a single or some diesel generators alone. HRES include RES such as wind and solar, energy storage system (ESS), and usually backup resource such as the diesel generator. Choosing RES depends on the individual properties of the remote region for example, the use of solar power is more suitable than wind power in a desert area such as Kerman in Iran. ESS stores excess free energy of RES and supplies remote region when renewable energy is inaccessible. If backup recourse does not exist, it is unavoidable to use high capacities of RES and ESS that is uneconomical.

Optimization of HRES is the subject of many research studies in HRES studies. The optimization objective can be designing, sizing, and controlling and managing energy that complete description written at review papers such as [3], [4], and [5].

Energy management system (EMS) in HRES includes two layers: the optimal scheduling layer and the real-time control layer. Main aims of the optimal scheduling layer are optimal operating of HRES and keeping the state of charge of the ESS in the reasonable range [6]. The reference [6] has proposed a model to fifteen-minute-ahead scheduling. Reference [7] believes that it is necessary to have an optimal strategy for power dispatch of HRES. This reference has proposed a model for optimal day-ahead scheduling based on a stochastic dynamic algorithm. The reference [8] has proposed the model predictive control (MPC) in order to dispatch energy in HRES and it has shown that if the diesel generator can charge the storage, the control results will be better than when diesel generator only supplies the load. These references assume variable output power for the diesel generator which needs a complex control system for remote regions and it is not

Corresponding author, E-mail:

practical. Besides, it affects the diesel generator lifetime. In order to minimize fuel consumption of the diesel generator and its cost, optimal day-ahead scheduling should be done [9], [10]. Reference [9] has considered multi-objective optimization to day-ahead scheduling and reference [10] has proposed a model to day-ahead scheduling diesel generator in an HRES based on minimizing fuel consumption and utilization of the diesel generator in the rated power but these references have not considered the uncertainty of the renewable resources specifically. Furthermore, the start of the diesel generator has not been modeled. PV-diesel-battery system is a kind of HRES components that can be used in many applications such as ships [11]. In this paper, optimal diesel generator day-ahead scheduling model (DDSM) of the PV-diesel-battery system has been proposed by using the genetic algorithm (GA). The output power of the diesel generator has been assumed constant and the start of it has been modeled. Uncertainty of solar power has been considered by Monte-Carlo simulation (MCS). The contribution of this paper includes:

- Proposing a practical model for scheduling of the remote HRES with no complication of the variable output power of diesel generator and fuel consumption function approximation.
- Considering uncertainty of the solar power in HRES scheduling by Monte-Carlo simulation using beta probability distribution function.
- Estimation of annual and five-year environmental, economic, and technical indexes based on the proposed dispatch strategy and comparing them in different reliability scenarios.

In the second section of this paper, DDSM and modeling of components of the PV-diesel-battery system have been proposed. Section three has been assigned to the results of the implementation of DDSM in a sample remote region and sensitivity analysis towards different parameters. The conclusions have been expressed in section four and finally, the references have been shown in the fifth section.

## 2- Proposed model

Hybrid renewable energy systems (HRES) include some parts; renewable energy resources (RES), energy storage, a backup energy resources (often diesel generator), electrical loads and control parts (converters and the unit of control and management). As shown in Fig. 1 in this paper HRES includes PV generator, battery, diesel generator, and load. As shown in Fig. 2 the output of the proposed model of this paper is to determine the optimal day-ahead scheduling of

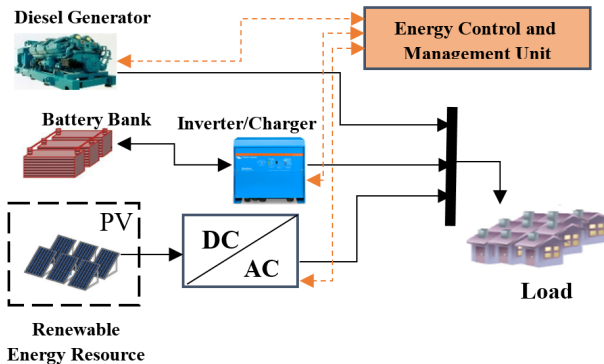

Fig. 1. The components of the HRES in a region.

the diesel generator. Input data are demand model and solar power that both of them are based on next day predictions. In order to model uncertainty, Monte-Carlo simulation has been considered. Optimization algorithm runs for each sample generated from input data and finally, the most frequent result is introduced as the output of the model. The model of the parts of the HRES, application of the Monte-Carlo simulation in DDSM, and optimization algorithm have been described as follows.

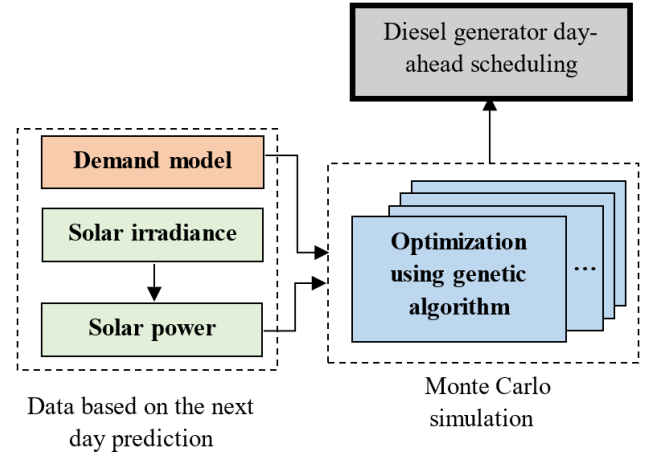

Fig. 2. Diesel generator Day-ahead Scheduling Model (DDSM)

### 2- 1- PV Model

In this paper, the generated power of PV resource has been modeled by linear function based on ambient temperature and plane of array irradiance [12]. The output power of PV resource in the HRES according to the maximum power point (MPP) has been computed from Eq. (1), where some parameters are related to the information in PV manufacture datasheets based on standard test condition (STC) and nominal operating cell temperature (NOCT).

$$P_{PV} = \left[ P_{PV,STC} \times \frac{G_T}{1000} \times \left[ 1 - \gamma \times (T_j - 25) \right] \right] \times N_{PV}, \quad (1)$$

where  $P_{PV}$ ,  $P_{PV,STC}$ ,  $G_T$ ,  $\gamma$ ,  $T_j$  and  $N_{PV}$  are the generated output power of PV modules at MPP, the maximum power of PV at STC, the plane of array irradiance in (W/m<sup>2</sup>), the power temperature coefficient at MPP in  $1/C$ , the cell temperature, and the number of PV modules respectively. The cell temperature is obtained from Eq. (2).

$$T_j = T_{amb} + \frac{G_T}{800} \times (NOCT - 20), \quad (2)$$

where  $T_{amb}$  and  $NOCT$  are the ambient temperature and the NOCT of the PV modules. In this paper, the PV generator is composed of mono-crystalline / N-type modules with 60 cells. It has been supposed that all modules are at the same temperature.

### 2- 2- Battery model

If there is no energy storage in the HRES, the diesel generator must be ON for a long period of time that causes more fuel consumption, more pollution and less lifecycle of the diesel generator. In addition, excess free renewable energy is wasted. Therefore, energy storage in the HRES is an effective and important part. However, in some applications for example solar pumps or grid-connected systems, the presence of an

energy storage system is not necessary. The battery can store electricity as chemical energy. It is economical and simple energy storage. In this work, LiFePo4 battery from the Lithium Ion category batteries has been used. Comparison between the kinds of batteries has been done in some research like [5, 13]. In the HRES, the state of charge in charging and discharging mode of the battery is obtained from Eq. (3) and Eq. (4), respectively [11].

$$SOC(t) = SOC(t-1) + \frac{(E_{t,ren} + E_{t,d} - E_{t,load})}{E_{B, rated}} \times \eta_{ch} \quad (3)$$

$$SOC(t) = SOC(t-1) - \frac{(E_{t,load} - E_{t,ren} - E_{t,d})}{E_{B, rated} \times \eta_{dis}} \quad (4)$$

where  $SOC(t)$  is the state of charge at the end of the  $t$  th period of time and  $E_{t,ren}$ ,  $E_{t,d}$ ,  $E_{t,load}(t)$  are the energy of the renewable resource, the diesel generator, the load demand at the  $t$  th period of time.  $E_{B, rated}$  is the rated energy of the battery.  $\eta_{ch}$ ,  $\eta_{dis}$  are the, the charging efficient and the discharging efficient of the chosen battery which are 0.85 and 1 respectively.

### 2- 3- Load Model

By predicting electrical consumption of the house loads and certain electrical consumption in time windows of the day using the load modeling method proposed by [9, 10], load profile of the HRES has been modeled for the middle days of the seasons. Time delay and demand factor are considered for housing.

### 2- 4- Diesel Generator Model

If the diesel generator participates at HRES frequency control via its governor directly, it is possible to create conflict between converters control operation and governor operation. In addition, the diesel generator output power fluctuates permanently. Power fluctuation of a diesel generator leads to the reduction of its lifecycle. Another reason for lifecycle reduction of the diesel generator is working other than rated power. For these reasons, the governor is assumed to be on the droop mode and set to the maximum possible frequency causing the generation of constant maximum possible power (rated power) by the diesel generator. This method is similar to the method of the diesel generator operation in [10].

The model and manufacturer of the diesel generator are known. Thus, the fuel consumption at a rated power of the diesel generator is known, too. The reduction of the change between ON and OFF states in the diesel generator in optimized scheduling causes an increase in its lifecycle. Therefore, in addition to normal fuel consumption, the fuel consumption in the start of the diesel generator has been modeled equivalent to 5 minutes running at the rated power [14]. Finally, the function of the diesel generator fuel consumption by considering 30-minute time periods is obtained as follows:

If diesel was running just before  $t$ ,

$$F(t) = 0.5F_{RP}, \quad (5)$$

else,

$$F(t) = 0.5F_{RP} + F_{START} \times (F_{RP}), \quad (6)$$

where  $F(t)$ ,  $F_{RP}$  and  $F_{START}$  are the diesel fuel consumption at  $t$  th period of time in liter, the fuel consumption at the rated power of the diesel generator from datasheets in  $\frac{liter}{h}$ , and a factor that is equivalent to 5 minutes running at the rated power.

### 2- 5- Uncertainty Model

Monte-Carlo simulation (MCS) has been used for modeling the solar power uncertainty in DDSM.  $M$  samples of the PV generation power are generated in MCS using generating random numbers from Beta probability distribution. Probability density function (pdf) of the Beta probability distribution is obtained from the following equations [15]:

$$pdf(P_{ren}(t)) = \frac{P_{ren}(t)^{\alpha-1} \times (1-P_{ren}(t))^{\beta-1}}{B(\alpha(t), \beta(t))}, \quad (7)$$

$$B(\alpha(t), \beta(t)) = \int_0^1 P^{\alpha(t)-1} \times (1-P)^{\beta(t)-1} dP, \quad (8)$$

where  $P_{ren}(t)$  and  $B(\alpha(t), \beta(t))$  are the renewable energy resources power and the Beta function at the  $t$  th period of time respectively.  $\alpha(t)$  and  $\beta(t)$  are the parameters of the Beta pdf at the  $t$  th period of time which are calculated from the following equations, respectively,

$$\alpha(t) = \frac{(1-\mu(t)) \times \mu(t)^2}{\sigma^2(t)} - \mu(t), \quad (9)$$

$$\beta(t) = \frac{1-\mu(t)}{\mu(t)} \alpha(t). \quad (10)$$

$\mu(t)$  and  $\sigma^2(t)$  are the mean equal to solar power prediction for the  $t$  th period of time and standard deviation of the solar power prediction for the  $t$  th period of time of all days of the season, respectively.

### 2- 6- Optimization Algorithm

500 iterations at GA have been used for optimization algorithm in DDSM. The constraints of the optimization are as follows:

$$P_{ren}(t) + P_d(t) + P_{ESS}(t) = P_{load}(t), \quad (11)$$

$$P_d(t) = 0 \text{ or } P_{d, rated}, \quad (12)$$

$$SOC(t) \geq SOC_{min}, \quad (13)$$

$$E_{t,ren} + E_{t,d} - E_{t,load} = E_{t,ESS}, \quad (14)$$

where  $P_d(t)$ ,  $P_{ESS}(t)$  and  $P_{load}$  are the momentum power of the diesel generator, the ESS, and the load.  $E_{t,ESS}$  and  $P_{d, rated}$  are the energy stored in ESS at the  $t$  th period of time and rated power of the diesel generator, respectively.

Optimization objective function (O.F.) is to maximize the fitness according to Eq. (15) equal to minimizing daily diesel fuel consumption.

$$O.F. = fitness = \frac{1}{\sum_{i=1}^{48} F(i)} \quad (15)$$

Flow chart of the algorithm has been shown in Fig. 3.

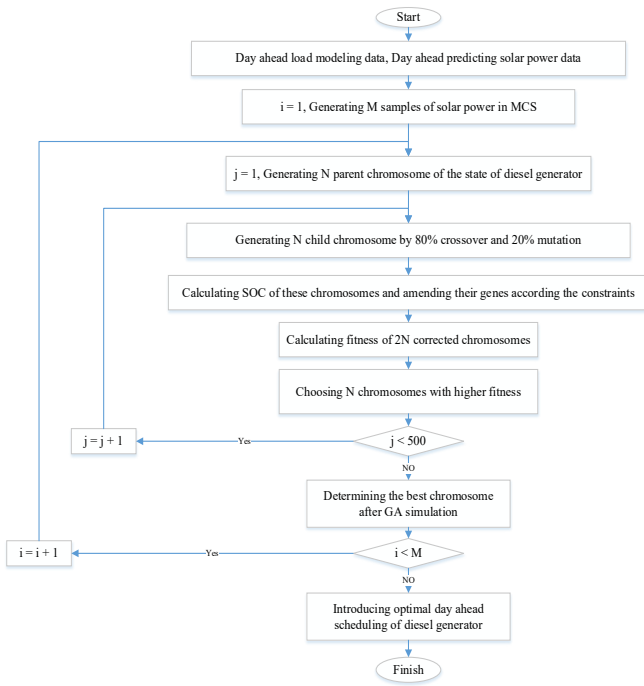

Fig. 3. Algorithm flowchart

2- 7- Estimation of the Annual Indexes

Because the scheduling method is known using DDSM, it can be used for designing HRES or annual evaluating of the designed HRES. As shown in Fig. 4, in this paper, the middle days of the seasons are considered and DDSM is implemented on them and then the results are extended to the whole year. In this paper, the annual indexes are yearly fuel consumption, the number of the starts of the diesel generator, duration of the time when the diesel generator is ON and finally the amount of the pollution obtained from fuel consumption computed from Eq. (16) [16].

$$CO_2 = F_y \times E_f, \tag{16}$$

where  $F_y$  and  $E_f$  are yearly fuel consumption and emission factor for the diesel generator, respectively. An emission factor is related to the type of fuel and the diesel engine

characteristics which have been considered 2.6 kg/l in this paper [16].

3- Numerical Studies

3- 1- Model implementation for a remote sample region

For numerical studies on the proposed model in section 2, a remote region in Kerman in Iran has been considered. Kerman is a desert area in Iran, As a result, the use of solar power is a reasonable solution to supply a remote region there. Solar data of the region were obtained from [16]. Load modeling of ten houses and one industrial workshop has been done for the sample days of the seasons as shown in Fig. 4. According to the figure, the peak of the load is in the summer and the maximum electrical energy of the load is in winter. After 200 iterations of the MSC in order to simulate the day in the summer with the input data as displayed in Table.1, the results are shown in Table.2. As a result, if uncertainty is not considered, optimal scheduling may not be the best scheduling.

Table 1. Input data of the under-study sample system

	$SOC(0)$	$SOC_{min}$	$P_{d, rated}$	$P_{PV, STC}$	$E_{B, rated}$	$N_{PV}$
value	0.4	0.4	12.9 KW	335 W	45 KWh	36

Table 2. Results of the GA simulation

	Duration time when the diesel generator is ON (minutes)	Number of the diesel generators started	Fuel Consumption (liter)	Frequent in MCS (%)
Best result	150	3	11.8	52
Second result	150	2	11.5	27
Third result	150	3	11.8	16

The best result has been shown in Fig. 5. According to this figure, there is no need to start the diesel generator in the middle of the day because the level of solar energy is high,

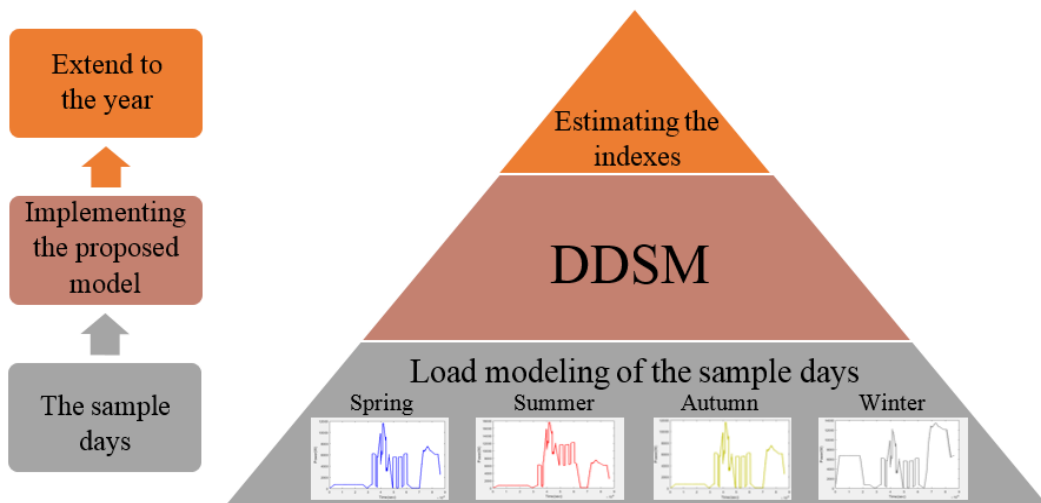
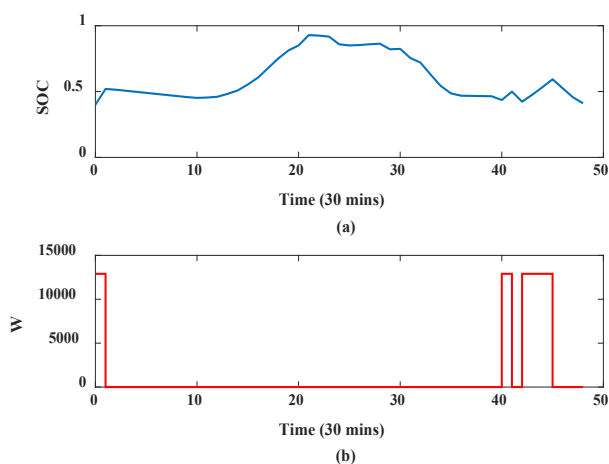

Fig. 4. The technique of annual evaluation of Diesel generator Day-ahead Scheduling Model (DDSM)



**Fig. 5. Optimal day-ahead scheduling by GA. (a) SOC of the battery. (b) Diesel generator output power**

but at the end of the day because of the increase in the load demand and absence of the solar energy, the diesel generator should be ON not to exceed the SOC constraint.

24-hour simulation of the system has been done and its results have been shown in Figs. 6 and 7. According to Fig. 6, optimal scheduled operation of the system runs with no problem. According to Fig. 7, estimated SOC is approximately similar to simulated SOC. The main reason of the difference between them is the constraint of the maximum battery charge current in the 24-hour simulation, another reason of the difference is the loss of power in resistant of lines in the 24-hour simulation that was not modeled in the GA simulation.

Nine scenarios have been considered in the first year of the operation of the system and the data from each scenario have been shown in Table 3. As shown in Table 4, annual indexes have been computed for these scenarios. Scenarios 2 and 3 could not supply the electrical loads because the capacity of both storage and diesel generator were low. Because of the low capacity of the storage in scenarios 6 and 9, the number of the diesel generator's starts would be very high causing its life to shorten. Furthermore, the duration of the diesel generator being ON is long, also it causes more fuel consumption and consequently more pollution. Thus, these scenarios like scenarios 2 and 3 are not appropriate, either. According to Table 4, it can be understood that scenario 4 is the best scenario from the point of view of the fuel consumption and pollution but scenario 7 is the best scenario from the point of view of the diesel generator operation and its lifetime because of less being ON and less number of its starting. Consequently, increasing the capacity of the diesel generator, in addition to increasing reliability causes an increase in the diesel generator lifetime. Also, when the capacity of the storage is chosen inappropriately, it causes the fuel consumption to grow fast. Scenario 1 is not appropriate because the duration at which the diesel generator is ON is long. In order to complete and develop the case study, the five-year operation of the system has been considered. It has been assumed that the electric consumption of the loads grows 5% every year. Scenarios 2, 3, 6 and 9 were not included in this study due to the above-mentioned reasons. Scenarios 1 and 5 were removed, too since these scenarios did not supply the loads in the next years.  $0.4 \frac{\$}{liter}$  has been considered for the diesel price [17] and the buying price of the diesel generator

and battery were determined based on [18, 11]. The five-year indexes and other data have been shown in Table 5.

Buying cost of the solar panels has been considered 12960\$ [19] and the final amount of the indexes of the whole system has been shown in Fig. 8. According to the figure, in scenario 4 in which the capacity of the storage is lower than the half of the others, total five-year costs of the system are the highest and consequently decreasing cost of buying equipment cannot decrease the total cost of the system necessarily that shows the capacity of the storage plays a key role in the costs. Furthermore, in this case, increasing reliability caused the total five-year cost and system's pollution to increase by about 8% and 13.4%, respectively. These numbers may be higher in another system with a larger scale. Scenario 7 compared to scenario 4 has both higher cost and higher pollution but it has two advantages. One of them is reliability indexes improvement and the other is the lower duration of the diesel generator being ON. These advantages mean less blackout and longer life of the diesel generator. Thus, the HRES planner should trade off and choose the best scenario among the existing choices.

### 3- 2- Sensitivity Analysis

In order to compare the effects of some parameters on the results, sensitivity analysis has been done by 24-hour simulation with constant scheduling according to Fig. 6.

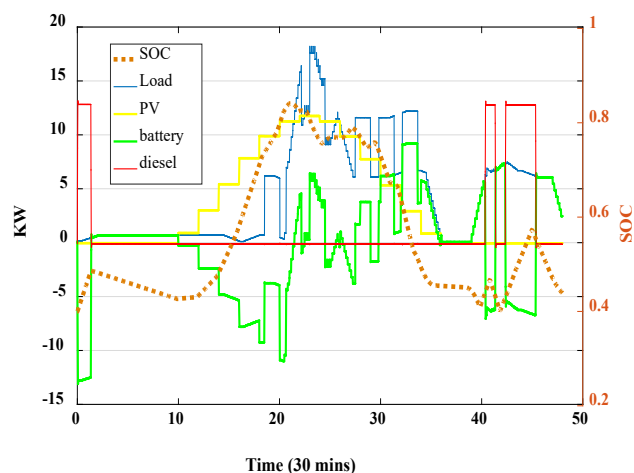

**Fig. 6. Results of 24-hour simulation**

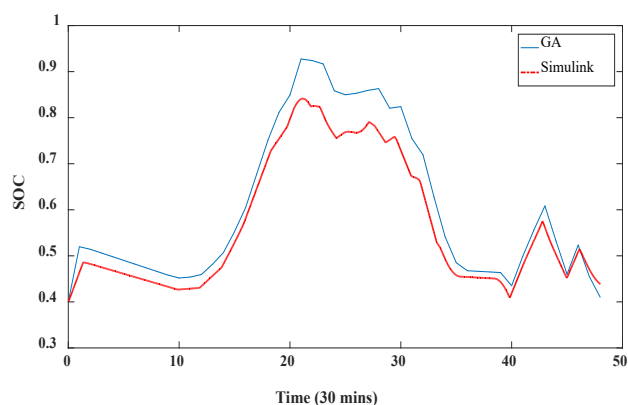

**Fig. 7. Comparison of the SOC of the battery between GA and 24-hour simulation**

**Table 3. Input data of the under-study sample system in different scenarios**

	Scenario 1	Scenario 2	Scenario 3	Scenario 4	Scenario 5	Scenario 6	Scenario 7	Scenario 8	Scenario 9
Properties	Low reliability and high storage capacity	Low reliability and intermediate storage capacity	Low reliability and low storage capacity	intermediate reliability and high storage capacity	intermediate reliability and intermediate storage capacity	intermediate reliability and low storage capacity	high reliability and high storage capacity	High reliability and intermediate storage capacity	High reliability and low storage capacity
$E_{B, rated}$	45 KWh	20 KWh	8 KWh	45 KWh	20 KWh	8 KWh	45 KWh	20 KWh	8 KWh
$P_{d, rated}$	7.3 KW	7.3 KW	7.3 KW	12.9 KW	12.9 KW	12.9 KW	18.7 KW	18.7 KW	18.7 KW
$F$	2.6	2.6	2.6	4.3	4.3	4.3	6.4	6.4	6.4

**Table 4. Results of the GA simulation for nine scenarios**

PV-diesel-battery	Scenario1	Scenario2	Scenario3	Scenario4	Scenario5	Scenario6	Scenario7	Scenario8	Scenario9
Annual number of the diesel generator is started	912	Could not supply	Could not supply	912	1184	2003	819	1091	2096
Annual duration of time when the diesel generator is ON (hours).	1852	Could not supply	Could not supply	1084	1404	1769	906	1133	1677
Annual fuel consumption (liter)	5012	Could not supply	Could not supply	4987	6361	8340	5933	7828	11846

**Table 5. Results of the five-year simulation for the chosen scenarios.**

PV-diesel-battery	Scenario 4	Scenario 7	Scenario 8
Total duration of time when the diesel generator is ON (hours).	6693	5070	6437
Annual fuel consumption (liter)	30568	34661	43442
Co2 (pollution in Kg)	79476	90120	112949
Diesel generator price (\$)	5562	6567	6567
Battery energy storage price (\$)	1890	1890	840
Equipment installation costs (\$)	7452	8457	7407
Total present value of the five-year fuel costs (\$)	11700	13282	16653
Total cost of the five-year of the system (\$)	19152	21739	24060

**3- 2- 1- Amount of power demand**

The amount of load model has been changed as much as  $\pm 10\%$ . The results have been shown in Fig. 9. It shows a 10 percent change in the amount of load causes SOC to change over  $\pm 20\%$ . Therefore, false load modeling may cause the diesel generator to be turned ON out of schedule.

**3- 2- 2- Amount of renewable energy resource power**

The amount of predicted PV power has been changed as much as  $\pm 10\%$ . The results have been shown in Fig. 10. It shows 10 percent change in the amount of predicted PV power due to SOC change about  $\pm 15\%$ . Thus false renewable energy resource power prediction may cause the diesel generator to be turned ON out of schedule, however, the sensitivity of the results toward load modeling are higher than toward renewable energy resource power.

**3- 2- 3- Turbulence in renewable energy resource power**

In order to generate turbulence in the simulation, random

numbers of a normal distribution function with the zero average and standard deviation equal to 1 KW were added to the predicted PV power. The results as shown in Fig.11 show no tangible change because SOC of the battery is related to energy and the energy has no tangible change in the presence of zero average turbulence.

**4- Conclusion**

In this paper, the diesel generator optimal day-ahead scheduling (DDSM) was proposed. It was a strategy for the power dispatch of the HRES focused on solar power in a remote region in a desert city such as Kerman in Iran. The output of DDSM was to determine the periods of time of the next day that the diesel generator should be ON. Calculations of DDSM was done by GA and uncertainty of the renewable energy resource considered by Monte-Carlo simulation using beta probability distribution function. The model was implemented in a sample remote HRES, including PV, battery and diesel generator in Kerman in Iran. In order to

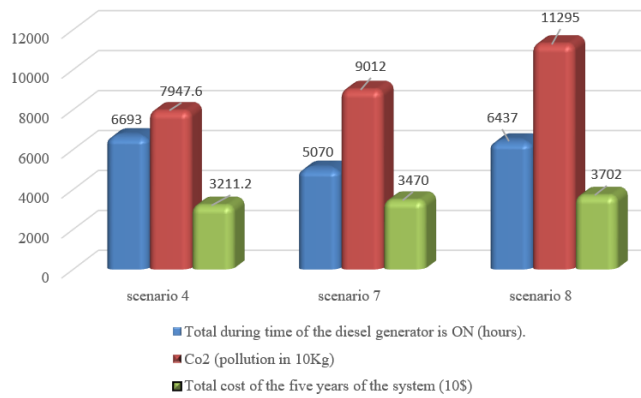

Fig. 8. Indexes of the five years of work of the system.

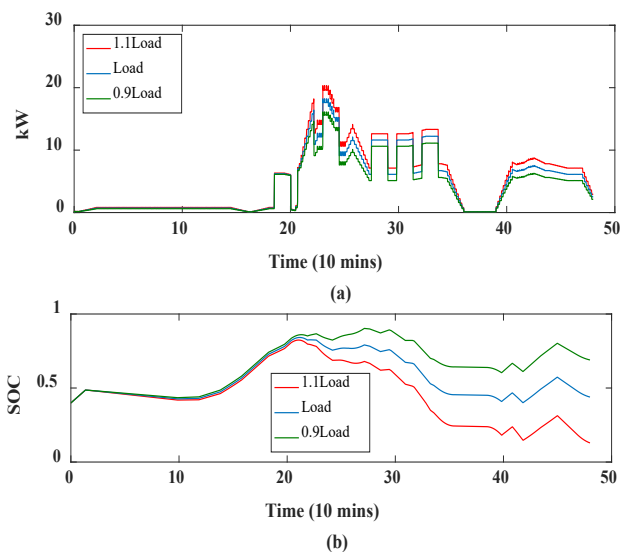

Fig. 9. Sensitivity analysis of power demand. (a) Changes in the load model. (b) Changes in the SOC of battery

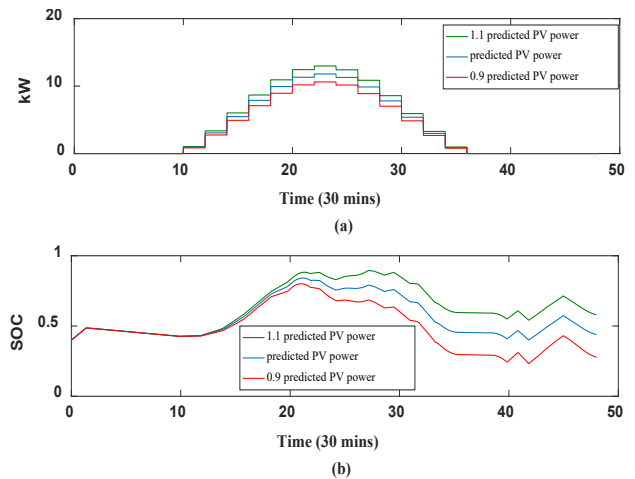

Fig. 10. Sensitivity analysis on solar power. (a) Changes in solar power. (b) Changes in the SOC of the battery

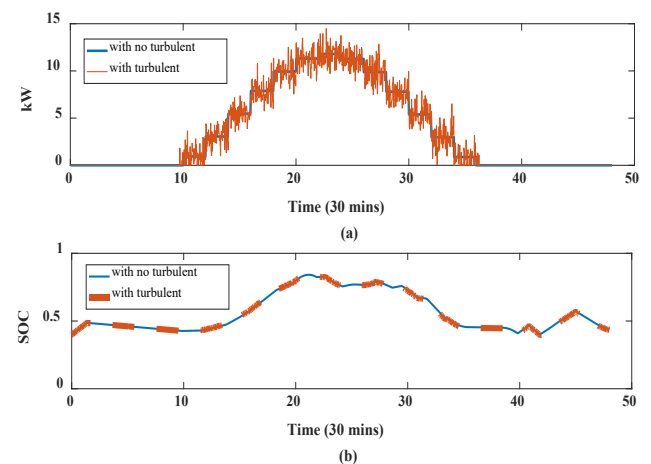

Fig. 11. Sensitivity analysis on the power demand. (a) Turbulence in solar power. (b) Changes in the SOC of the battery

validate the algorithm, a 24-hour simulation of the system was done. Annual indexes based on the proposed DDSM was estimated in different scenarios. Most important conclusions of the paper are:

- The objective function had no complication and uncertainty of solar energy was modeled. Thus, DDSM is an appropriate model for practical cases.
- The minimum fuel consumption was reached. As a result, pollution was minimized.
- Choosing low rate power diesel generator is not appropriate because it should be left ON for more time, especially when the demand energy increases in the next years, it is probable that the system collapses.
- Choosing a high rate power diesel generator necessarily decreases fuel consumption.
- Distribution system authority should trade-off between environmental, economic, and technical factors and choose the best option. It should consider growing loads of consumption in the coming years, too.
- Scheduling is sensitive to load modeling more than renewable resource power prediction.
- Scheduling is not sensitive to the turbulence of renewable energy resource.

## References

- [1] Gan, L.K., J.K. Shek, and M.A. Mueller, *Optimisation sizing of hybrid wind-diesel systems using linear programming technique.* (2014).
- [2] Ogunjuyigbe, A., T. Ayodele, and O. Akinola, Optimal allocation and sizing of PV/Wind/Split-diesel/Battery hybrid energy system for minimizing life cycle cost, carbon emission and dump energy of remote residential building. *Applied Energy*, 171(2016). 153-171.
- [3] Tezer, T., R. Yaman, and G. Yaman, Evaluation of approaches used for optimization of stand-alone hybrid renewable energy systems, *Renewable and Sustainable Energy Reviews*, 73 (2017) 840-853.
- [4] Nehrir, M., et al., A review of hybrid renewable/alternative energy systems for electric power generation: Configurations, control, and applications, *IEEE Transactions on Sustainable Energy*, 2(4) (2011) 392-403.
- [5] Fathima, A.H. and K. Palanisamy, Optimization in microgrids with hybrid energy systems—A review. *Renewable and Sustainable Energy Reviews*, 45 (2015) 431-446.
- [6] Wang, C., et al., Energy management system for stand-

- alone diesel-wind-biomass microgrid with energy storage system. *Energy*, 2016. 97: p. 90-104.
- [7] Hu, Y., et al., Dynamic multi-stage dispatch of isolated wind–diesel power systems, *Energy conversion and management*, 103 (2015) 605-615.
- [8] Tazvinga, H., B. Zhu, and X. Xia, Energy dispatch strategy for a photovoltaic–wind–diesel–battery hybrid power system, *Solar Energy*, 108 (2014) 412-420.
- [9] Chalise, S., et al., Energy management of remote microgrids considering battery lifetime, *The Electricity Journal*, 29(6) (2016) 1-10.
- [10] Gan, L.K., J.K. Shek, and M.A. Mueller, Optimised operation of an off-grid hybrid wind-diesel-battery system using genetic algorithm. *Energy Conversion and Management*, 126 (2016) 446-462.
- [11] Lan, H., et al., Optimal sizing of hybrid PV/diesel/battery in ship power system. *Applied energy*, 158 (2015) 26-34.
- [12] Riffonneau, Y., et al., Optimal power flow management for grid connected PV systems with batteries. *IEEE Transactions on sustainable energy*, (3)2 (2011) 309-320.
- [13] Tan, X., Q. Li, and H. Wang, Advances and trends of energy storage technology in microgrid, *International Journal of Electrical Power & Energy Systems*, 44(1) (2013) 179-191.
- [14] Cristóbal-Monreal, I.R. and R. Dufo-López, Optimisation of photovoltaic–diesel–battery stand-alone systems minimising system weight, *Energy Conversion and Management*, 119 (2016) 279-288.
- [15] Bludszuweit, H., J.A. Domínguez-Navarro, and A. Llombart, Statistical analysis of wind power forecast error, *IEEE Transactions on Power Systems*, 23(3) (2008) 983-991.
- [16] Yahiaoui, A., K. Benmansour, and M. Tadjine, Control, analysis and optimization of hybrid PV-Diesel-Battery systems for isolated rural city in Algeria. *Solar Energy*, 137 (2016) 1-10.
- [17] Available from: [http://www.globalpetrolprices.com/diesel\\_prices/](http://www.globalpetrolprices.com/diesel_prices/).
- [18] Available from: <http://www.china-power-contractor.cn/Perkins-Diesel-Generator-Price-List.html> /.
- [19] Available from: <https://www.freecleansolar.com/335W-solar-panel-LG335N1C-A5-NeON2-Cell10-p/lg335n1c-a5.html>.

Please cite this article using:

A. Alimardani, Sh. Jadid, Optimum scheduling of the HRES for an isolated rural city in Iran , *AUT J.*

*Elec. Eng.*, 51(1) (2019) 13-20.

DOI: 10.22060/ej.2019.13946.5197

