



New criteria for the existence of a switching controller for output signal shaping

Mahdieh Hosseingholizadeh Alashti, Jafar Heyrani Nobari*

K.N.Toosi University of technology, Tehran, Iran.

ABSTRACT: Although numerous advanced and intelligent controllers have been invented during the last years, classical PID controllers are still of interest to many control engineers and promising candidates for industrial purposes. In this study, the authors study the issue of when a switching controller gains exist to asymptotically track a predefined output profile for second-order linear time-invariant systems. This paper proposes several new criteria to ascertain the existence of the gains of PID controllers so that the output be in predefined values at special times. Since permitted output range is calculated for the nonzero initial values, we can switch between several PID gains in several steps to have a specific variation of output with time. In this way, several desired targets can be achieved without any compromising. It is the main goal of this paper. In fact, a scenario is considered for the output which determines its values in several times and these times generate time intervals over which variable gains are applied to the system. Requirements for tracking can be readily achieved with choosing the output value according to the criteria. It is evaluated by several simulation examples, which demonstrate that the proposed approach works well to obtain PID controller parameters in a guaranteed way.

Review History:

Received: Sep. 23, 2019

Revised: Feb. 19, 2020

Accepted: Feb. 29, 2020

Available Online: Jun. 15, 2020

Keywords:

Tracking controllers

Output regulation

Switching control

Control equations

PID controllers

1- INTRODUCTION

Proportional-integral-derivative (PID) controllers have been the most popular and the most commonly used industrial controllers during the past years. The popularity and widespread use of PID controllers are primarily attributed to their simplicity and performance characteristics. PID controllers have been utilized to control varieties of dynamical systems ranging from the industrial processes to aircraft, robots and ship dynamics. [1-6]

Although fixed-gain PID controllers are usually adequate for controlling a physical process, the requirements for a better control performance with variations in the operating conditions or environmental parameters are often beyond the capabilities of simple PID controllers. In order to improve the performance of simple PID controllers, many approaches have been developed to increase the adaptability and robustness by adopting the self-tuning method, general predictive control, fuzzy logic, nonlinear PID and neural networks strategy, and other methods [7–15].

In adaptive methods, controller gains are founded based on the changes in system parameters, like the cases reported in [16]. However, in this paper, the PID controller gains for an invariable and specific system are determined such that the output has special values at predefined times.

Classical methods like Ziegler-Nichols try to tune suitable PID gains by studying the step response of the system [17].

*Corresponding author's email: nobari@eetd.kntu.ac.ir

Artificial intelligence algorithm tries to find the best gains of the PID controller based on an objective function. Some researchers can reach a better transient and steady state response by combing classical methods with intelligent ones [18]. In this paper, a different approach is considered with emphasis on the step response of the system over desired time intervals and PID gains are determined with a novel way such that for different intervals different gains are founded and applied to the system.

In classic control, the desired response is defined in terms of parameters such as maximum overshoot, settling time, rising time and steady-state error. However, in this paper, the desired response of the system is defined via specific output values at predefined times. It means that quantized output values are the only effective parameter in determining PID gains and the only target at this step is to set the output at time T at value $y(T)$ determined by the designer. But the designer should know the admissible output range to make the right scenario. And it is proposed in several criteria in this paper.

Although the output profile between switched times is important, now it doesn't matter in this paper; it can overshoot, undershoot, and so on. Control effort is not also considered current and will be the next problem. In this work, our focus is on point viewing to the output and the existence of the PID gains. After exploring the problem of existence of the gains, in Section 8 some important points in this regard will be discussed.



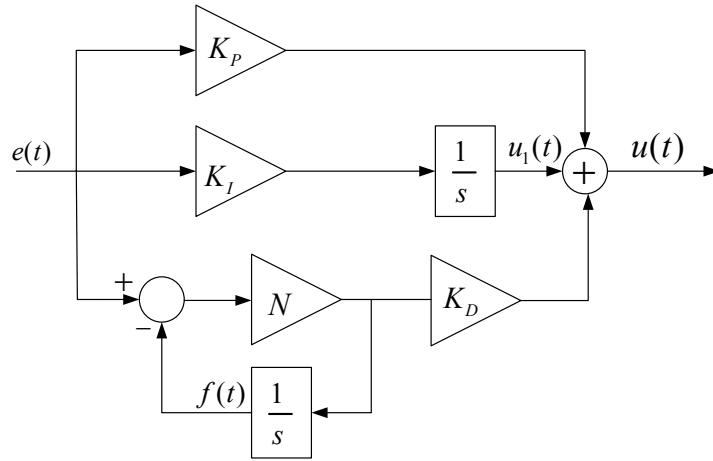

Fig. 1. Block diagram of implemented PID controller

Notice that results of this paper are true for a second order system or higher order system than can be approximated to a second order system. With appropriate choice of $y(T)$ values; according to the presented criteria; PID gains will be achieved for sure (existence of the gains).

Since the results are presented for nonzero initial values, it would be possible to determine variable gains at intervals such that the output is at specific values at predefined consecutive time spans. This is by considering the fact that, following-up the output from the predetermined scenario is the ultimate goal of this article.

These subjects are presented in Sections 2 to 6, where, the permissible output range is calculated for different types of the closed-loop system roots. For different cases of closed loop roots, examples are proposed that PID gains are calculated using Matlab functions, then closed-loop system Simulink is simulated, and the output and control signals are displayed. All of these examples confirm the correctness of the fact that the correct choice of $y(T)$ will certainly lead us to the PID controller's gains. Finally, as an example, a scenario is defined for a specific output and PID gains are tuned accordingly. Some important points about the output behavior between two switches is discussed in Section 8 and the paper is concluded in Section 9.

2- THE ARGUMENT

In this article, a second order system without zero in the form of $\frac{1}{s^2+a_1s+a_0}$ is considered. Input of the system is a step and initial value of the output and its derivative are y_0 and \dot{y}_0 . PID controller is considered in the practical form of $K_p + \frac{K_I}{s} + K_D \frac{N}{1+N\frac{1}{s}}$ and is implemented as Fig. 1.

If three roots of the closed-loop are s_1, s_2 and s_3 , the relations between roots and controller gains would be:

$$\begin{cases} a_1 + K_D = -(s_1 + s_2 + s_3) \\ a_0 + K_P = s_1s_2 + s_1s_3 + s_2s_3 \\ K_I = -s_1s_2s_3 \end{cases} \quad (1)$$

By partial fraction decomposition, the output equation at

specific time T is:

$$y(T) = 1 + e^{s_1T} \frac{A_1}{(s_1 - s_2)(s_1 - s_3)} + \quad (2)$$

$$e^{s_2T} \frac{A_2}{(s_2 - s_1)(s_2 - s_3)} + e^{s_3T} \frac{A_3}{(s_3 - s_1)(s_3 - s_2)}$$

$$A_i = s_i^2 y_0 + s_i (a_1 y_0 + \dot{y}_0 + K_D - K_D f(0)) + K_P + u_1(0) + \frac{K_I}{s_i}, i = 1, 2, 3$$

To calculate signal f at the end of each step of switch which is used as an initial value for the start of the next switch, the below equation will be used.

$$f(T) = 1 - e^{-NT} + f(0)e^{-NT} - 1 - e^{s_1T} \frac{NA_1}{(s_1 + N)(s_1 - s_2)(s_1 - s_3)} \quad (3)$$

$$- e^{s_2T} \frac{NA_2}{(s_1 + N)(s_2 - s_1)(s_2 - s_3)} - e^{s_3T} \frac{NA_3}{(s_1 + N)(s_3 - s_1)(s_3 - s_2)}$$

And the value of u_1 at the end of each step of switch which is used as the initial value of the integrator part in the next step would be:

$$u_1(T) = a_0 - \frac{B_1 K_I e^{s_1 T}}{s_1^2 (s_1 - s_2)(s_1 - s_3)} - \quad (4)$$

$$\frac{B_2 K_I e^{s_2 T}}{s_2^2 (s_2 - s_1)(s_2 - s_3)} - \frac{B_3 K_I e^{s_3 T}}{s_3^2 (s_3 - s_1)(s_3 - s_2)}$$

$$B_i = s_i^3 y + s_i^2 (K_D - K_D f(0) + a_1 y_0 + \dot{y}_0) + s_i (K_P + u_1(0)) + K_I, i = 1, 2, 3$$

Now it should be determined that at a definite time T for what value of the output the designer can be sure of the existence of PID gains. The answer is that if the output range is selected according to presented criteria, then there will be PID gains. These criteria will be discussed later in Sections 3

to 5, and the output range will be obtained for different types of closed loop roots.

3- THREE CLOSED LOOP ROOTS ARE REAL AND WITH THE SAME SIGN

The difficulty of exploring the problem in three dimensions is simplified by examining the output in the discontinuities and the boundaries of the root zone. Main discontinuities of the output for three same sign roots summarized in three cases:

Case A: $s_1 \rightarrow 0, s_2 \rightarrow 0 \Rightarrow E_1(s_3)$

Case B: $s_1 \rightarrow s_2, s_2 \rightarrow s_3 \Rightarrow E_2(s_3)$

Case C: $s_1 \rightarrow 0, s_2 \rightarrow s_3 \Rightarrow E_3(s_3)$

In the following, the discontinuity expressions are calculated for different values of the same sign roots of the closed-loop system.

3.1. Three closed loop roots are real, distinct and negative

The discontinuity case A: in this case:

$$\lim_{s_3 \rightarrow 0} E_1(s_3) = y_0 - \frac{T^2(a_0 - u_1(0))}{2} + T(\dot{y}_0 - a_1 + a_1 y_0 + a_1 f(0))$$

$$\lim_{s_3 \rightarrow -\infty} E_1(s_3) = 1 - f(0)$$

In the following, suppose $K_L = y_0 - \frac{T^2(a_0 - u_1(0))}{2} + T(\dot{y}_0 - a_1 + a_1 y_0 + a_1 f(0))$.

The discontinuity case B: in this case:

$$\lim_{s_3 \rightarrow 0} E_2(s_3) = K_L$$

$$\lim_{s_3 \rightarrow -\infty} E_2(s_3) = 1$$

The discontinuity case C: in this case:

$$\lim_{s_3 \rightarrow 0} E_3(s_3) = K_L$$

$$\lim_{s_3 \rightarrow -\infty} E_3(s_3) = 1$$

By calculating other limits for two closed loop roots are the same, real and negative and the third one is real and negative and also for three closed loop roots are the same, real and negative, the following lemma will be obtained.

For all lemmas in this paper suppose a second order system without zero and with nonzero initial values that is controlled by a PID controller.

Lemma 1: If three negative closed loop roots are desired, the presence of the output in the range of $[\min(K_L, 1, 1 - f(0)), \max(K_L, 1, 1 - f(0))]$ at a specific time T guarantees the existence of the controller gains. If three roots are also equal, the output range must be $[\min(K_L, 1), \max(K_L, 1)]$. The occurrence of extreme in E_1, E_2 or E_3 can enlarge upper

or lower boundary.

It should be noted that in practice, the initial value of the derivative part i.e. $f(0)$ must be $1 - y_0$ in the first switch, and in the following switches, its value is determined using equation (3).

3.2. Three closed loop roots are distinct, real and positive

The discontinuity case A: in this case with respect to the great value of N:

$$\lim_{s_3 \rightarrow 0} E_1(s_3) = K_L$$

$$\lim_{s_3 \rightarrow +\infty} E_1(s_3) = -\infty \times \text{sign}_{\text{roots}}(M_{\text{inf}})$$

Where

$$M_{\text{inf}} = s_i^2(1 - y_0 - f(0)) + s_i(a_1 - \dot{y}_0 - a_1 y_0 - a_1 f(0)) + (a_0 - u_1(0)) \quad i \in \{1, 2, 3\}$$

And to determine the sign of M_{inf} roots, suppose that Root1 and Root2 are its roots. So,

$$\text{if } (\text{Root1} \times T) > T_h \text{ or } (\text{Root2} \times T) > T_h \rightarrow \text{sign}_{\text{Roots}} > 0$$

$$\text{if } (\text{Root1} \times T) < -T_h \text{ or } (\text{Root2} \times T) < -T_h \rightarrow \text{sign}_{\text{Roots}} < 0$$

$$\text{else } \text{sign}_{\text{Roots}} = 0$$

The value of T_h can be determined by finding the number making e^{T_h} infinite. For example, if $e^8 = 2.9e^3$ can be considered as an infinite number then T_h is 8.

The sign of M_{inf} roots should be considered since s_3 has positive value and it can affect the result only if the sign of greater roots of M_{inf} is positive and the output range becomes $(-\infty, +\infty)$. This is because of the change in sign of M_{inf} before and after this big root. Otherwise, the sign of the largest root power factor; that is $1 - y_0 - f(0)$ in this case of discontinuity; determines the output range.

The discontinuity case B: in this case:

$$\lim_{s_3 \rightarrow 0} E_2(s_3) = K_L$$

$$\lim_{s_3 \rightarrow +\infty} E_2(s_3) = -\infty \times \text{sign}(1 - y_0 - 3f(0))$$

The discontinuity case C: in this case:

$$\lim_{s_3 \rightarrow 0} E_3(s_3) = K_L$$

$$\lim_{s_3 \rightarrow +\infty} E_3(s_3) = -\infty \times \text{sign}(1 - y_0 - 2f(0))$$

By calculating limits for two closed loop roots are the same, real and positive and the third one is real and positive and also for three closed loop roots are the same, real and positive the following lemma will be obtained.

Lemma 2: If the desire is three positive closed-loop roots and if three roots are the same, the output range become

$(-\infty \times \text{sign}(1-y_0-3f(0)), K_L]$. Otherwise it would be:

$$\begin{aligned} & \text{if } \text{sign}_{\text{Roots}}(M_{\text{inf}}) \leq 0 \\ & \rightarrow \begin{cases} \text{if } \text{sign}(1-y_0-f(0)), \text{sign}(1-y_0-2f(0)), \text{sign}(1-y_0-3f(0)) > 0 \rightarrow y(T) \in (-\infty, K_L) \\ \text{if } \text{sign}(1-y_0-f(0)), \text{sign}(1-y_0-2f(0)), \text{sign}(1-y_0-3f(0)) < 0 \rightarrow y(T) \in [K_L, +\infty) \\ \text{else } \rightarrow y(T) \in (-\infty, +\infty) \end{cases} \end{aligned}$$

$$\text{if } \text{sign}_{\text{Roots}}(M_{\text{inf}}) > 0 \rightarrow y(T) \in (-\infty, +\infty)$$

4- THREE CLOSED LOOP ROOTS ARE REAL AND WITH DIFFERENT SIGN

4.1. Three closed loop roots are real, distinct; two of them are negative and, one of them is positive

Assume that s_1 is positive and s_2, s_3 are negative. So, the output range is obtained for the following cases.

$$\text{Case A: } s_2 \rightarrow 0, s_3 \rightarrow 0 \Rightarrow Z_1(s_1)$$

$$\text{Case B: } s_2 \rightarrow s_3, s_3 \rightarrow -s_1 \Rightarrow Z_2(s_1)$$

$$\text{Case C: } s_2 \rightarrow 0, s_3 \rightarrow -s_1 \Rightarrow Z_3(s_1)$$

$$\text{Case D: } s_2 \rightarrow 0, s_1 \rightarrow 0 \Rightarrow Z_4(s_3)$$

$$\text{Case E: } s_2 \rightarrow s_3, s_1 \rightarrow -s_3 \Rightarrow Z_5(s_3)$$

$$\text{Case F: } s_1 \rightarrow 0, s_2 \rightarrow s_3 \Rightarrow Z_6(s_3)$$

We need to define:

$$N_{\text{inf}} = s_1^2(1-y_0+f(0)) + s_1(a_1-\dot{y}_0-a_1y_0-a_1f(0)) + a_0-u_1(0) \quad (5)$$

$$L_{\text{inf}} = s_1^2(1-y_0) + s_1(a_1-\dot{y}_0-a_1y_0-a_1f(0)) + a_0-u_1(0)$$

$$N_{n\text{-inf}} = s_1^2(1-y_0+f(0)) + s_1(-a_1+\dot{y}_0+a_1y_0+a_1f(0)) + a_0-u_1(0)$$

$$L_{n\text{-inf}} = s_1^2(1-y_0) - s_1(a_1-\dot{y}_0-a_1y_0-a_1f(0)) + a_0-u_1(0)$$

And $N_{n\text{-inf}}$ and $L_{n\text{-inf}}$ are the same as N_{inf} and L_{inf} in which s_1 coefficient becomes negative.

Lemma 3: If the desire is two real and negative closed-loop roots and one positive root, at specific time T the output range is:

$$\begin{aligned} & \text{if } \text{sign}_{\text{Roots}}(M_{\text{inf}}) \leq 0 \ \& \ \text{sign}_{\text{Roots}}(N_{\text{inf}}) \leq 0 \ \& \ \text{sign}_{\text{Roots}}(L_{\text{inf}}) \leq 0 \\ & \left\{ \begin{aligned} & \text{if } \text{sign}(1-y_0), \text{sign}(1-y_0-f(0)), \text{sign}(1-y_0+f(0)) > 0 \Rightarrow y(T) \in (-\infty, \max(1-f(0), 1, K_L)] \\ & \text{if } \text{sign}(1-y_0), \text{sign}(1-y_0-f(0)), \text{sign}(1-y_0+f(0)) < 0 \Rightarrow y(T) \in [\min(1-f(0), 1, K_L), +\infty) \end{aligned} \right. \\ & \text{else } \Rightarrow y(T) \in (-\infty, +\infty) \end{aligned}$$

By calculating limits for two closed loop roots are the same, negative and real; the third one is real and positive the following lemma will be obtained.

Lemma 4: If the desire is two similar and real and negative closed-loop roots and one positive root, at specific time T the output range is:

$$\begin{aligned} & \text{if } \text{sign}_{\text{Roots}}(M_{\text{inf}}) \leq 0 \rightarrow \begin{cases} \text{if } \text{sign}(1-y_0), \text{sign}(f(0)) < 0 \Rightarrow y(T) \in [\min(K_L, 1), +\infty) \\ \text{if } \text{sign}(1-y_0), \text{sign}(f(0)) > 0 \Rightarrow y(T) \in (-\infty, \max(K_L, 1)] \end{cases} \\ & \text{else } \Rightarrow y(T) \in (-\infty, +\infty) \end{aligned}$$

4.2. Two closed loop roots are real, distinct and positive; the third one is real and negative

Assume that s_2 is negative and s_1, s_3 are positive. Therefore, the important output discontinuity cases are:

$$\text{Case A: } s_1 \rightarrow 0, s_3 \rightarrow 0 \Rightarrow Z_1(s_2)$$

$$\text{Case B: } s_1 \rightarrow s_3, s_3 \rightarrow -s_2 \Rightarrow Z_2(s_2)$$

$$\text{Case C: } s_1 \rightarrow 0, s_3 \rightarrow -s_2 \Rightarrow Z_3(s_2)$$

$$\text{Case D: } s_2 \rightarrow 0, s_1 \rightarrow 0 \Rightarrow z_4(s_3)$$

$$\text{Case E: } s_2 \rightarrow -s_3, s_1 \rightarrow s_3 \Rightarrow Z_5(s_3)$$

$$\text{Case F: } s_1 \rightarrow 0, s_2 \rightarrow -s_3 \Rightarrow Z_{6n}(s_3)$$

$$\text{Case G: } s_2 \rightarrow 0, s_3 \rightarrow s_1 \Rightarrow Z_7(s_1)$$

By calculating limits for this case following lemma will be obtained:

Lemma 5: If the desire is two distinct and real and positive closed-loop roots and one negative root, at specific time T the output range is:

$$\begin{aligned} & \text{if } \text{sign}_{\text{Roots}}(M_{\text{inf}}) \leq 0 \ \& \ \text{sign}_{\text{Roots}}(L_{\text{inf}}) \leq 0 \\ & \left\{ \begin{aligned} & \text{if } \text{sign}(1-y_0), \text{sign}(1-y_0-f(0)), \\ & \text{sign}(1-y_0-2f(0)) > 0 \Rightarrow \\ & y(T) \in (-\infty, \max(1-f(0), K_L)] \\ & \text{if } \text{sign}(1-y_0), \text{sign}(1-y_0-f(0)), \\ & \text{sign}(1-y_0-2f(0)) < 0 \Rightarrow \\ & y(T) \in [\min(1-f(0), K_L), +\infty) \end{aligned} \right. \\ & \text{else } \Rightarrow y(T) \in (-\infty, +\infty) \end{aligned}$$

By calculating limits for two closed loop roots are the same, positive and real; the third one is real and negative and considering O_{inf} as below following lemma will be obtained.

$$\begin{aligned} O_{\text{inf}} &= s_i^2(1-y_0-2f(0)) + \\ & s_i(a_1-\dot{y}_0-a_1f(0)-a_1y_0) + a_0-u_1(0), i=1, 2, 3 \end{aligned} \quad (6)$$

Lemma 6: If the desire is two similar, real and positive closed-loop roots and one negative root, at specific time T the output range is:

$$\begin{aligned} & \text{if } \text{sign}^{n_{\text{Roots}}}(O_{\text{inf}}) \leq 0 \ \& \begin{cases} \text{if } \text{sign}(f(0)), \text{sign}(1-y_0-2f(0)) < 0 \Rightarrow \\ y(T) \in [\min(1-f(0), K_L), +\infty) \\ \text{if } \text{sign}(f(0)), \text{sign}(1-y_0-2f(0)) > 0 \Rightarrow \\ y(T) \in (-\infty, \max(1-f(0), K_L)] \end{cases} \\ & \text{else} \Rightarrow y(T) \in (-\infty, +\infty) \end{aligned}$$

5- TWO CLOSED LOOP ROOTS ARE COMPLEX AND WITH NEGATIVE REAL PART

5.1. Third root is real and negative

Assume that the two roots s_1 and s_2 are $\sigma \pm i\omega$ and s_3 is another root. Starting from equation (7):

$$\begin{aligned} y(T) = & 1 + e^{s_3 T} \frac{s_3^2(y_0 - 1 + f(0)) + s_3(\dot{y}_0 + a_1 y_0 - a_1 + a_1 f(0) + 2\sigma f(0)) - a_0 + u_1(0)}{(s_3 - \sigma)^2 + \omega^2} \quad (7) \\ & - \frac{e^{\sigma T}}{((s_3 - \sigma)^2 + \omega^2)} \left[\frac{\sin(\omega T)}{\omega} ((s_3 - \sigma)\alpha - \omega^2 \beta) + \cos(\omega T) ((s_3 - \sigma)\beta + \alpha) \right] = y_3(T) \end{aligned}$$

Where,

$$\begin{aligned} \alpha = & \begin{pmatrix} \sigma^2(y_0 - 1) + \omega^2(1 - y_0) + \\ \sigma \dot{y}_0 + \sigma a_1 y_0 - \sigma a_1 - a_0 + \\ u_1(0) + \sigma(2\sigma + s_3 + a_1)f(0) \end{pmatrix} \quad (8) \\ \beta = & 2\sigma y_0 + \dot{y}_0 + a_1 y_0 - (2\sigma + a_1)(1 - f(0)) + s_3 f(0) \end{aligned}$$

And the relation between the roots and the controller's gains is as:

$$\begin{cases} K_D = -2\sigma - s_3 - a_1 \\ K_P = \sigma^2 + \omega^2 + 2\sigma s_3 \\ K_I = -(\sigma^2 + \omega^2) s_3 \end{cases}$$

So,

$$\lim_{\omega \rightarrow 0} y_3(T) = y_4(T) \quad (9)$$

And,

$$\alpha_0 = \begin{pmatrix} \sigma^2(y_0 - 1) + \sigma \dot{y}_0 + \sigma a_1 y_0 - \sigma a_1 \\ -a_0 + u_1(0) + \sigma(2\sigma + s_3 + a_1)f(0) \end{pmatrix}$$

$$\lim_{s_3 \rightarrow \sigma} y_4(T) \rightarrow \begin{cases} \text{if } \sigma \rightarrow 0 \Rightarrow K_L \\ \text{if } \sigma \rightarrow -\infty \Rightarrow 1 \end{cases}$$

$$\lim_{s_3 \rightarrow \sigma} y_3(T) = y_5(T) \quad (10)$$

$$\text{if } \omega \rightarrow 0 \Rightarrow 1 + \frac{1}{2} e^{\sigma T} (2\beta T + T^2 \alpha + 2(y_0 - 1)) \rightarrow$$

$$\begin{cases} \text{if } \sigma \rightarrow 0 \Rightarrow K_L \\ \text{if } \sigma \rightarrow -\infty \Rightarrow 1 \end{cases}$$

$$\text{if } \omega \rightarrow +\infty \Rightarrow 1 - e^{\sigma T} \cos(\omega T)(1 - y_0) \rightarrow$$

$$\begin{cases} \text{if } \sigma \rightarrow 0 \Rightarrow 1 - \cos(\omega T)(1 - y_0) \in [2 - y_0, y_0] \\ \text{if } \sigma \rightarrow -\infty \Rightarrow 1 \end{cases}$$

Lemma 7: If the desire is two complex roots with negative real part and one negative real root, at specific time T the output range is:

$$[\min(K_L, 1, 2 - y_0, y_0), \max(K_L, 1, 2 - y_0, y_0)]$$

By calculating limits for Third root is real and positive the following lemma will be obtained.

Lemma 8: If the desire is two complex roots with negative real part and one positive real root, at specific time T the output range is:

$$\text{if } \text{sign}_{\text{Root}}(N_{n-\text{inf}}) \leq 0 \Rightarrow y(T) \in (-\infty, +\infty)$$

$$\text{if } \text{sign}_{\text{Root}}(N_{n-\text{inf}}) \geq 0 \Rightarrow$$

$$\begin{cases} \text{if } \text{sign}(1 - y_0 + f(0)) < 0 \rightarrow \\ y(T) \in [\min(K_L, 2 - y_0, y_0, 1), +\infty) \\ \text{if } \text{sign}(1 - y_0 + f(0)) > 0 \rightarrow \\ y(T) \in (-\infty, \max(K_L, 2 - y_0, y_0, 1)] \end{cases}$$

By calculating limits for two closed loop roots are complex and with positive real part the following lemma will be obtained.

Lemma 9: If the desire is two complex roots with positive real part and one real root. Output can take any value which lead us to PID gains.

6- CALCULATION OF $\dot{y}(T)$

It is necessary to specify the value of the output derivative at the end of each interval to be the initial value of the output derivative or \dot{y}_0 for the next time interval. So:

$$\dot{y}(T) = A_1 e^{s_1 T} + A_2 e^{s_2 T} + A_3 e^{s_3 T} \quad (11)$$

Where:

$$A_i = \frac{s_i^2 y_0 + s_i(a_1 y_0 + \dot{y}_0 + K_D - K_D f(0)) + K_P + u_1(0) + \frac{K_I}{s_i}}{(s_i - s_j)(s_i - s_k)}$$

$, j, k \neq i = 1, 2, 3$

Also, according to lemmas, there are some constraints that the designer has to notice and steps should be taken one after the other according to the lemmas. The following example is a sample of this design.

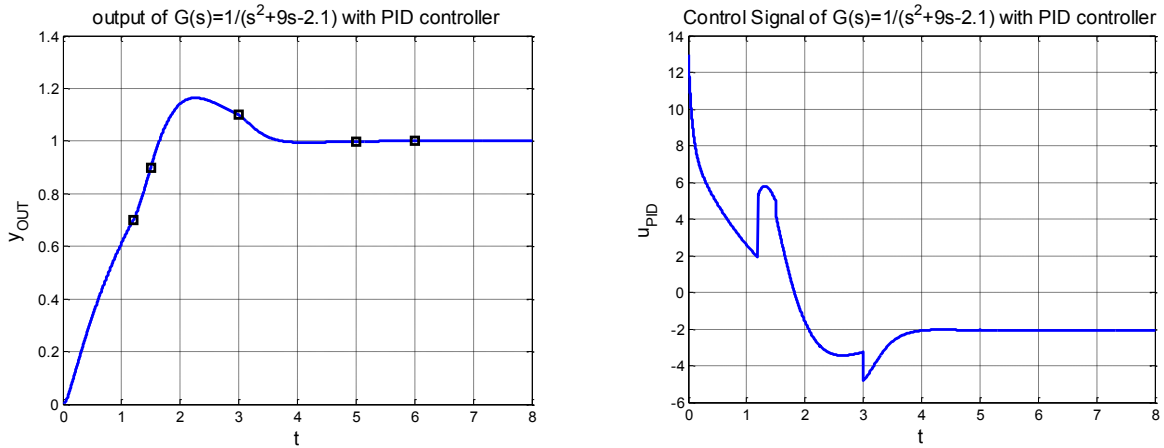

Fig. 2. the output and control signal of example.

Example- Suppose that second order system is $\frac{1}{s^2+9s-2.1}$, and initial values are zero. So what would be the values of PID gains such that the output values are $[0.7, 0.9, 1.1, 0.99, 1]$ at times $[1.2, 1.5, 3.5, 6]$? In the first, third and fifth intervals three roots are distinct and negative. And in second and fourth intervals two roots are complex with a negative real part and, the other root is negative and real.

Answer: Roots (s_3, s_2, s_1) in the first, second, third, fourth and fifth intervals are calculated to be $(-0.67, -0.075, -14.4)$, $(-1.87 \pm 0.27j, -1.25)$, $(-2.28, -2.31, -2.34)$, $(-4.33 \pm 3.5 \times 10^{-6}j, -1.97)$ $(-4.146, -4.143, -4.089)$ respectively.

K_p gains at consecutive intervals $[T_5, T_4, T_3, T_2, T_1]$ are $[53.17, 37.97, 18.1, 10.37, 12.94]$, K_I gains are $[70.24, 37.05, 4.48, 4.48, 0.73]$ and K_D gains are $[3.37, 1.64, -2.06, -4.62]$.

The value of the output derivative at consecutive intervals take the value of $[0.00013, 0.003, -0.11, 0.77, 0.4]$, the value of u_i are $[-2.09, -2.1, -1.21, 0.83, 0.55]$. The value of f are $[1.3 \times 10^{-9}, 0.0018, -0.10, 1, 0.3]$.

The admissible range of the output for case 1, 2, 3, 4 and 5 are $[0, 1.512]$, $[0.7, 1.3]$, $[0.9, 5.35]$, $[0.9, 2.64]$ and $[0.98, 1]$ respectively. Output and control signal are obtained as illustrated in Fig. 2.

As shown in the above example, since the last controller was stable, the closed-loop system becomes and remains stable. In this regard, the following theorem is necessary.

Stability theorem: The necessary and sufficient condition for the stability of this method is the stability of the last controller.

Proof: A time-invariant linear system without initial conditions will be BIBO stable if the output of any bounded input is bounded and finite. Since in designing the scenario the output values at mid-point times are imposed by the designer, they are limited. So, the only problem is that what happens to the output after the last imposition. The stability of final controller which makes the output bounded and finite can address this concern. It means that the given condition is sufficient. On the other hand, it is clear that if the final controller is unstable, there would be an input which can make the output infinite.

7- ADMISSIBLE OUTPUT RANGE WITH LIMITATION ON DOMAIN OF CONTROL SIGNAL

Lemmas 1-9 get admissible output range in several cases of closed-loop roots. Output ranges obtained without regarding any limitation in control effort. But in real applications control effort must be limited, for example because of the limitation of actuator inputs. If we consider a saturation block after controller block then the admissible output range would be the subset of ranges states in lemmas. To find this subset for each switch we can check it in initial and final time of each switch. If we consider $|u(t)| < U_m$ we must check:

$$\begin{aligned} &|K_p(1-y(t_0)) - K_D \dot{y}(t_0)| < U_m \\ &\left| \begin{aligned} &K_p(1-y(T_f)) - K_D \dot{y}(T_f) + \\ &K_I(T_f - t_0)(1-y(T_f)) \end{aligned} \right| < U_m \end{aligned} \quad (12)$$

In above inequalities $y(t_0)$ and $\dot{y}(t_0)$ are known in each switch. When $y(T_f)$ have specific value, system roots are calculated and the value of $\dot{y}(T_f)$ and three controller gains will be determined.

Assume that $[\psi, \eta]$ is the admissible output range for a special system that is obtained using lemmas in this paper. To start finding admissible subset of this range in present of actuator saturation in a special switch $[t_0, T_f]$ we must consider lower limit ψ and increase it step by step until inequalities (12) be satisfied (i.e. $y(T_f) = \psi$). So new lower limit ψ will be found. Then increase ψ until inequalities (12) aren't satisfied. So the upper limit η will be found. In this way, subset of admissible output range in the present of saturation is $[\psi, \eta]$. And this new subset should be considered during design phase.

8- COMPARISON WITH OTHER TUNING METHODS

Among lots of PID tuning methods, we can compare our method with those which are suitable for second order systems and in time domain. We select two methods. First one is a method that Haeri presented in [19] and, first, normalized

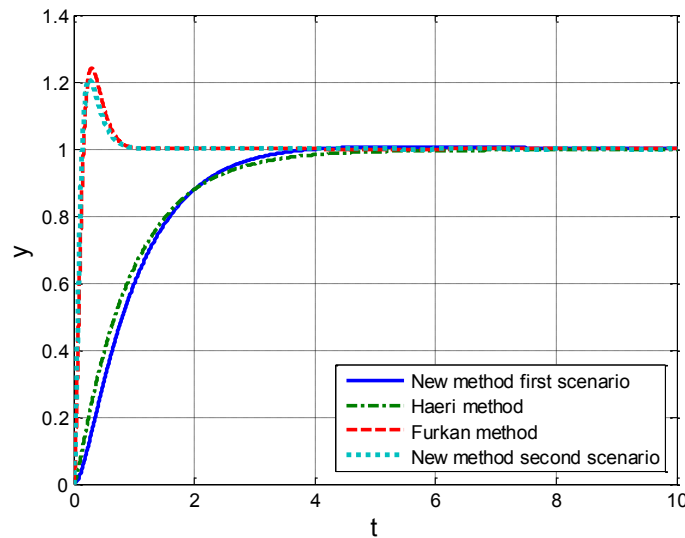

Fig. 3. Output signal of a second order system with PID gains of several methods.

PID parameters for under damped systems using a curve-fitting algorithm are obtained. Then, PID gains formulas are given with these normalized parameters. In [20] other method is presented by Furkan and PID design is implemented by a multiple pole placement strategy which enforces the control system had real poles with a desired time constant specification. These two methods have analytic solution but our method has numeric solution. Haeri method are suitable only for under damped second order systems and Furkan method only consider time constant specification while our method is so general by point viewing to output value in time T. These methods cannot be used for switching PID but our method special application is for switching PID to give several desired specification simultaneously. To compare our method with these two methods an under damped system like simulation 2 in [19] is considered. This system is $G(s) = \frac{3}{s^2 + s + 3}$. We consider $\tau = 0.1$ for Furkan method and high stability margin in Haeri method. For better comparison, we use our method in two scenarios. First scenario is $y(2) = 0.878$ which is obtained from Haeri method output and second scenario is $y(0.3) = 1.2$ which is obtained from Furkan method. PID parameters in Haeri method are $K_p = 8.38, K_i = 0.992$ and $K_D = 7.78$ and in our first scenario are $K_p = 2.16, K_i = 1$ and $K_D = 2.16$. As shown in Fig. 3, our method result with first scenario is very similar to Haeri method result. PID parameters in Furkan method are $K_p = 98.99, K_i = 333.3$ and $K_D = 9.66$ and in our second scenario are $K_p = 157, K_i = 553.2$ and $K_D = 12.94$. As shown in Fig. 3, our second scenario result are very similar to Furkan method result. Although our method is solved numerically, it is so general and can lead us to PID gains for every scenario that you want. In addition, considering initial state values in this paper formulas make our method suitable for switching PID design.

9- IMPORTANT POINTS

Point 1- According to lemmas, it may be concluded that if there are two complex roots with a positive real part, then there

will be PID gains for each amount of the output. Therefore, the other cases of lemmas would not be valuable. However, what is overlooked in this point of view is that although the focus of this study is on point viewing to the output, its behavior is also important at times between two switches. The existence of complex roots means that there are oscillations in the output profile. Therefore, due to the constraints on control efforts in the real system, these behaviors between the two switches may not be desirable. So, when the designer refers to lemmas, should notice the behavior of the output between the two switches in addition to the existence of PID gains. Each kind of roots will create a type of output behavior and, this is the value of each cases of lemmas. Also, in the last switch, there must be three stable roots.

As an example, as shown in Fig. 5, for four different combinations of closed loop roots, four different behaviors are seen in the interval between two switches. In the fourth case (two complex roots with positive real part and a positive root), the output has a high overshoot, but the second case (two complex roots with negative real part and a positive root) and the third one (two complex roots with positive real part and a negative root) have no overshoot. The first case (two complex roots with a negative real part and a negative root) has also a slight overshoot. The designer may prefer to one of these four cases for a particular study.

Point 2- The final values of $y(T), f(T)$ and $u_1(T)$ are used as the initial values $y_0, f(0)$ and $u_1(0)$ in the next switch which help to the smoothing of the output signal, the control signal of the derivative part and the control signal of the integrator part at the moment of switching respectively.

Point 3- The result of load disturbance and even system parameters uncertainty is that the output at final time of a switch is not exactly in its expected value. So we can change PID gains or next switch plans to concur this problem. If we know that disturbance occurs after last switch, we can design last PID scenario based on good disturbance rejection. Also, if we doesn't know the exact value of system parameters but

know the bound of variations, we can change output admissible range by considering low or high limit of parameters bound. It can be done because admissible output range in lemmas are stated in parametric forms.

10- CONCLUSION

In this paper, the permissible output range of system with switching PID controller which can be approximated by a non-zero second-order system has been calculated. The main output of this paper is that it is possible to set a specific profile for the output in the time domain based on the switching steps and changing the control gain because the admissible range of the output calculated for nonzero initial condition. It means that if a scenario is arranged for the output determining its value at a few moments, then these moments form the time intervals over which switched gains can be obtained using our proposed method.

Several lemmas has been proposed that a designer can shape the output signal with confidence if consider them. So, simultaneous achievement to several desired targets become possible and switching controller makes it.

REFERENCES

- [1] Åström, Karl Johan and Hägglund, Tore, "PID controllers: theory, design, and tuning", *Instrument society of America Research Triangle Park, NC*, volume 2, (1995).
- [2] M. H. Korayem, A. Imanian, H. Tourajizadeh and et al., "A Novel Method for Simultaneous Control of Speed and Torque of the Motors of a Cable Suspended Robot for Tracking Procedure", *Scientia Iranica*, 20, pp. 1550,1565,(2013).
- [3] Mohammad D. Hasankola, Abbas Ehsaniseresht, Majid M.Moghaddam, et al., "Analysis, modeling, manufacturing & control of an elastic actuator for rehabilitation robots", *Scientia Iranica*, 22, pp.1855–1865, (2015).
- [4] H Matsuki, T Nishiyama, Y Omori, et al., "Flight test of fault-tolerant flight control system using simple adaptive control with PID controller", *Aircraft Engineering and Aerospace Technology*, 90, pp. 210–218, (2018).
- [5] X Hu, C Li, Y Yu, et al., "DESIGN OF UNMANNED SHIP HEADING CONTROLLER BASED ON FCMAC-PID", *Academic Journal of Manufacturing Engineering*, 16,(2018).
- [6] O Khan, CMR Madhuranthakam, P Douglas, at al." Optimized PID controller for an industrial biological fermentation process", *Journal of Process Control*, 71, pp. 75-89, (2018).
- [7] Mohammad Reza Gharib, Majid Moavenian, "Synthesis of Robust PID Controller for Controlling a Single Input Single Output System Using Quantitative Feedback Theory Technique", *Scientia Iranica*, 21, pp. 1,(2014).
- [8] Y Wang, Q Jin, R Zhang, "Improved fuzzy PID controller design using predictive functional control structure", *ISA transactions*, 71, pp. 354–363, (2017).
- [9] K Borgeest, PJ Schneider, "PID, Fuzzy and Model Predictive Control Applied to a Practical Nonlinear Plant", *International Journal of Robotics Applications and Technologies (IJRAT)*, 4, pp. 19-42, (2016).
- [10] K Lu, W Zhou, G Zeng, et al, "Design of PID controller based on a self-adaptive state-space predictive functional control using extremal optimization method", *Journal of the Franklin Institute*, 355, pp. 2197-2220, (2018).
- [11] J Zhang, "Design of a new PID controller using predictive functional control optimization for chamber pressure in a coke furnace", *Isa Transactions*, 67, pp.208-214, (2017).
- [12] SM Attaran, R Yusof, H Selamat, "A novel optimization algorithm based on epsilon constraint-RBF neural network for tuning PID controller in decoupled HVAC system", *Applied Thermal Engineering*, 99, pp.613-624, (2016).
- [13] A Agrawal, V Goyal, P Mishra, "Adaptive Control of a Nonlinear Surge Tank-Level System Using Neural Network-Based PID Controller", *Applications of Artificial Intelligence Techniques in Engineering*, pp. 491-500, (2019).
- [14] J Zhao, J Zhong, J Fan, "Position control of a pneumatic muscle actuator using RBF neural network tuned PID controller", *Mathematical Problems in Engineering*, 2015, (2015).
- [15] L Liu, F Pan, D Xue, "Variable-order fuzzy fractional PID controller", *ISA transactions*, 55, pp. 227-233, (2015).
- [16] M. Shahrokhi, "Comparison of Four Adaptive PID Controllers", *Scientia Iranica*, 7, (2000).
- [17] Saranya, M and Pamela, D, "A real time IMC tuned PID controller for DC motor", *International Journal of Recent Technology and Engineering*, 1, pp. 65–70, (2012).
- [18] Erenoglu, Isin and Eksin, Ibrahim and Yesil, Engin and Guzelkaya, Mujde, "An intelligent hybrid fuzzy PID controller", *European Conference on Modelling and Simulation*, pp. 62–67, (2006).
- [19] Mohammad Haeri, "Tuning rules for the PID controller using A DMC strategy", *Asian Journal of Control*, Vol. 4, No. 4, pp. 410-417, December 2002.
- [20] Furkan Nur Deniz, Baris Baykant Alagoz, Nusret Tan, "PID controller design based on second order model approximation by using stability boundary locus fitting", 2015 9th International Conference on Electrical and Electronics Engineering (ELECO).

HOW TO CITE THIS ARTICLE

M. Hosseingholizadeh Alashti, J. Heyrani Nobari, *New criteria for the existence of a switching controller for output signal shaping*, *AUT J. Model. Simul.*, 52(1) (2020) 89-96.

DOI: [10.22060/miscj.2020.17092.5172](https://doi.org/10.22060/miscj.2020.17092.5172)

